



Student Booklet

LANGUAGE

2



Education
Quality and
Accountability
Office

Please note: The format of these booklets is slightly different from that used for the assessment. The items themselves remain the same.

Bobby's Big Toe

Bobby didn't comb his hair. His socks were never pulled up, his shoelaces were always undone and he never tucked in his shirt. Bobby would dump his school bag, books and jacket on the floor when he came home from school. At dinner, he would quickly finish his meal, leaving a messy table, and he never helped with dinner dishes. When Bobby got ready for bed, his clothes stayed where they landed. Bobby was not neat. Being tidy was NOT one of Bobby's characteristics.

1

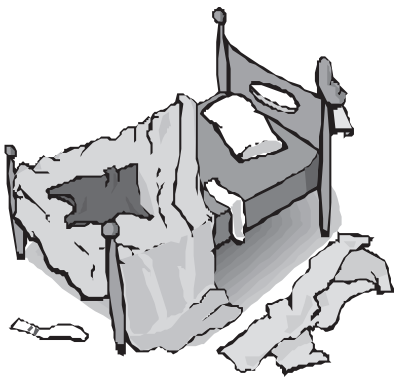

Each night when Bobby was asleep, his mother would slip into his room and collect his dirty clothes. She was getting tired of cleaning up after her son. "I wish Bobby would put his grubby clothes into the laundry hamper. What can I do to make Bobby clean up after himself?" his mother asked herself.

2

Bobby's mother suddenly had an idea. She knew something that Bobby didn't. She knew that after he snuggled into bed, he would take the covers and pull them up tight to his neck. She also knew he would stretch out his right leg as far as he could. Because his covers were all pulled up around his neck, his right foot would stick out of the covers.

3

That night, Bobby's mother was ready to put her plan into action. She quietly entered Bobby's room and gathered all his dirty clothes. She then took a ball of string and, piece by piece, began to tie Bobby's dirty clothes together like the tail of a kite. It took her a long time to do this because Bobby had so much dirty clothing. Once the dirty clothes were tied together, she tied the end of the string to Bobby's big toe. Bobby slept with the string tied to his big toe all night.

4

- Morning dawned bright and sunny. Bobby sat up, yawned and rubbed his eyes. 5
- As he rolled over to get out of bed, Bobby felt something pulling on his big toe. He stopped, feeling confused, and looked down at his big toe. There, attached to his big toe, was a piece of string. 6
- Bobby pulled on the string. From under his bed, from beside his dresser, from the window ledge, things were moving. Each tug on the string produced a surprise—yesterday’s underwear, a sweater, socks and his jeans appeared from their hiding places. 7
- “Ahem,” said Bobby’s mom. 8
- Bobby looked up to see her in the doorway. 9
- Bobby laughed out loud. He looked around his room, and he couldn’t believe all the dirty clothes that were strung together. “I’ve heard about tying a string on your finger to help you remember something, but I’ve never heard of a string on the big toe!” 10

- 1** Which would be the best new title for this story?
- A Good Night's Rest
 - A Sore Toe for Bobby
 - The Big Ball of String
 - Bobby Learns a Lesson *
- 2** What is the setting of this story?
- Bobby's school
 - Bobby's kitchen
 - Bobby's bedroom *
 - Bobby's living room
- 3** What is the main idea of this story?
- Bobby's room has a comfortable bed.
 - Bobby's covers are up around his neck.
 - Bobby's clothes are hanging in his closet.
 - Bobby's mother makes a plan to teach him a lesson. *
- 4** At the beginning of the story, Bobby is
- tidy.
 - proud.
 - helpless.
 - disorganized. *

5 How long does Bobby’s mother wait to carry out her plan after she thinks of it?

- one day *
- two days
- three days
- four days

6 List four examples from the story that show that Bobby is untidy. Use information from the text and your own ideas in your answer.

7 Explain why Bobby’s mother decides to tie a string around his big toe. Use information from the text and your own ideas in your answer.

8 In paragraph 4, it takes Bobby's mother a long time to tie all his dirty clothes to the string because

- there is lots of dirty clothing. *
- she is tired from working all day.
- it is hard to tie the string to all the clothes.
- she has a hard time seeing in the dark room.

9 Why is Bobby confused when he wakes up?

- His big toe hurts.
- His mother is in the doorway.
- He feels something pulling on his big toe. *
- He has to get up too early in the morning.

10 How does Bobby probably feel when he pulls on the string and his dirty clothes start moving?

- proud
- angry
- amazed *
- frightened

11 In paragraph 4, the author uses the phrase “like the tail of a kite” to describe

- how Bobby’s bedcovers look.
- how messy Bobby’s bedroom looks.
- how Bobby’s mother ties the clothes together. *
- how Bobby’s leg looks sticking out of the covers.

12 Explain what kind of person you think Bobby’s mother is and tell why you think this. Use information from the text and your own ideas in your answer.

13 In paragraph 7, why does the author write that the dirty clothes “appeared from their hiding places”?

- Bobby’s clothes had been lying on his bed.
- Bobby had put all his clothes under the dresser.
- Bobby had hidden his clothes before he went to bed.
- Bobby’s clothes had been lying everywhere around the room. *

14 Why is there an exclamation mark (!) at the end of the last sentence?

- to show anger
- to show surprise *
- to show someone is talking
- to show it is the end of the story

15 After Bobby learns to put his dirty clothes into the laundry hamper, what will his mother probably try to teach him next?

- to go to bed earlier in the evening
- to wake up earlier in the morning
- to put his things away after school *
- to eat his dinner without wasting time

16 Predict how Bobby’s behaviour will change once he realizes why his mother has tied the string to his toe. Use information from the text and your own ideas in your answer.

Writing Multiple-Choice

17 Read the sentence below.

The brown puppy jumped quickly out of the box and ran to Louis.

Which of the following words are used correctly as verbs in the sentence?

- box, ran
- jumped, ran *
- brown, puppy
- jumped, quickly

18 Which of the following correctly divides the word “transportation” into syllables?

- transporta-tion
- trans-portion
- tran-sport-ation
- trans-por-ta-tion *

19 Read this sentence.

All the _____ jumped in the _____.

Which of the following pairs of words correctly completes the sentence?

- childs, leafs
- childs, leaves
- children, leafs
- children, leaves *

20 Read the sentence below.

The old boat floated slowly down the river.

Which of the following is correctly used as an adverb in the sentence?

- old
- river
- slowly *
- floated

Going Batty

Bats, bats, everywhere.

They hang from here; they hang from there.

Bats find the perfect place to roost,
in trees and under bark.

They hang from branches upside down 5
and see best in the dark.

When the sun is setting,
bats ready to take flight.

Finding food is their big job, 10
these creatures of the night.

Some bats are just fruit eaters,
while others just eat meat.

Vampire bats drink mammal blood;
some catch fish with their feet.

Brown bats do eat mosquitoes— 15
'round 600 an hour.

They spread seeds for new plants and trees;
they're small with mighty power.

Bats help rebuild cut forests
and save many crops from harm. 20

Wouldn't you like to have
a few bats upon your farm?

In some ways they're like kittens—
they lick their fur so clean.

Bats fly by using hands and wings,
yet rarely are they seen.

25

Most bats have a special gift—
using echoes to locate.

With two keen ears to steer the way,
just watch them navigate!

30

As mammals go, the bat's unique.

Please, let me tell you why:

The bat's the only mammal
that can really fly!



- 21** According to the poem, which statement is true?
- Bats are able to see well in daylight.
 - Bats have little strength for their size.
 - Different kinds of bats have different diets. *
 - Farmers must have bats to make their crops grow.
- 22** Why does the author use an apostrophe at the beginning of line 16?
- to show that someone is speaking
 - to show how the poem should be read
 - to show that a letter has been left out *
 - to show that the author owns the poem
- 23** According to the text, how do bats help rebuild cut forests?
- They eat leaves.
 - They scatter seeds. *
 - They eat nearby crops.
 - They hang from the trees.

- 24** Do you think “Going Batty” is a good title for this poem? Use information from the text and your own ideas in your answer.

- 25** Read the sentence below.

Wouldn't you like to have / a few bats upon your farm?

Why does the author use a question mark at the end of the sentence?

- to ask something *
- to show belonging
- to show excitement
- to make a statement

- 26** In the poem “Going Batty,” how are bats and kittens alike?

- They “lick their fur.” *
- They “save many crops.”
- They can “steer the way.”
- They use “echoes to locate.”

27 After reading the poem, what are your feelings about bats? Use information from the text and your own ideas in your answer.

28 You find a box with a key on the playground at recess.

Here is a picture of some boxes with keys.

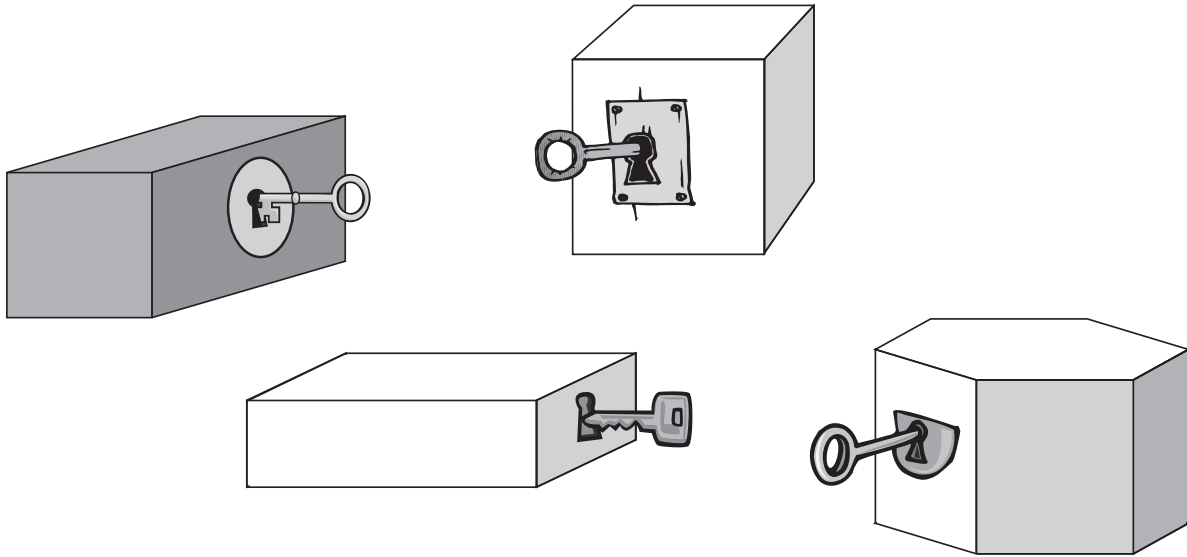

Ideas for My Story

Remember:

- Check over your work.
- Check your spelling, grammar and punctuation.

- 29** Read the sentence. Part of the sentence is missing.

Mohamed and Carol _____ to the park.

Which of the following correctly completes the sentence?

- going
- are going *
- is going
- goes

- 30** Which of the following words begins with a prefix?

- usually
- unhappy *
- umbrella
- understand

- 31** Read the sentences in the box below.

The children were playing at recess. They played tag. They skipped rope at recess.

Which of the following is the best way to combine these sentences?

- At recess the children play tag and skip.
- The children playing tag and skipping rope.
- The children played tag and skipped rope at recess. *
- The children played skipping at recess and played tag at recess.

- 32** Which word below goes with “butter” to make a compound word?

- fly *
- wind
- jump
- quick

The Sleepover

Sultana was excited about the baby soon to be born. Everything was planned for the big day. When her parents had to go to the hospital, Sultana was to stay with some neighbours. 1

Sultana liked Mr. and Mrs. Lee. They had lived in the house next door ever since Sultana and her parents moved in. They had always been kind to her family, bringing over cookies and looking after Sultana when her mother had doctor's appointments. 2

But Sultana had never spent the whole night at the Lees' house. The truth was, she was afraid. What if she woke up in the middle of the night with a bad dream or a stomach ache? 3

When the big day finally arrived, Sultana waited and waited with Mr. and Mrs. Lee to hear some news. Long after Sultana's usual bedtime, they were still waiting. After midnight, the telephone rang. 4

"It's a girl!" shouted Sultana's father. "She is beautiful; she looks just like you when you were born." 5

"When can I see her?" asked Sultana. 6

"We will all be home tomorrow," answered her dad. "We love you!" 7

Sultana hung up the telephone. She felt warm all over. At last she was a big sister! Big sisters should be able to handle new situations. She would be brave. 8

Before Mrs. Lee tucked her back into bed, Sultana kissed a picture of her family goodnight. 9

33 Read this sentence from the text.

They had lived in the house next door ever since Sultana and her parents moved in.

In the sentence, “They” refers to

- Mr. and Mrs. Lee. *
- Sultana’s parents.
- Sultana and her sister.
- Sultana and her brother.

34 How does Sultana feel about sleeping at the Lees’?

- angry
- happy
- worried *
- surprised

35 Describe the setting for the story “The Sleepover.” Use information from the text and your own ideas in your answer.

36 According to the text, at what time does Sultana’s father call from the hospital?

- at bedtime
- late at night *
- before supper
- in the afternoon

37 Read this sentence from the text.

“When can I see her?” asked Sultana.

Why does the writer use quotation marks?

- to show that Sultana is upset
- to show that Sultana is excited
- to show what Sultana is saying *
- to show that someone is with Sultana

38 Which sentence best describes how Sultana feels at the end of the story?

- She is happy. *
- She is confused.
- She is surprised.
- She is disappointed.

39 How does Sultana feel about being a big sister? Use information from the text and your own ideas in your answer.



The information in this booklet is being collected under authority of clause 4 (1) (b) and subsection 9 (6) of the *Education Quality and Accountability Office Act, 1996*, for the purposes of administering and marking tests of pupils in elementary schools and evaluating the quality and effectiveness of elementary education, in accordance with section 3 of the Act. Inquiries regarding this collection should be directed to the Senior Policy Analyst, EQAO, 1-888-327-7377.

Student responses in this booklet may be used as examples for the marking of the assessment, and may be included without attribution in public reports.

© 2006 Queen's Printer for Ontario.

All rights reserved. No part of this publication may be reproduced, stored in a retrieval system, or transmitted in any form or by any means, electronic, mechanical, or otherwise, without the prior express written permission of the Education Quality and Accountability Office.

