

# Student Booklet

# **MATHEMATICS**



Education  
Quality and  
Accountability  
Office

Please note: The format of these booklets is slightly different from that used for the assessment. The items themselves remain the same.



# Section

# 1

1. The triangle PQR has been transformed to the position XYZ.

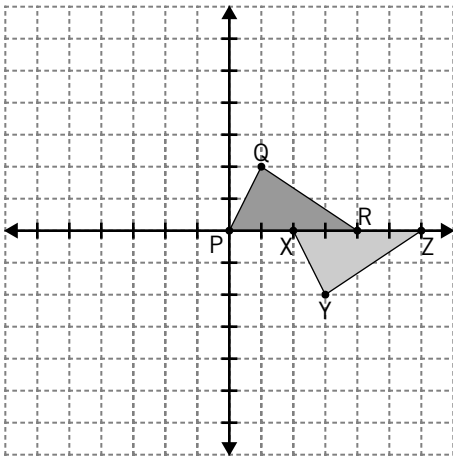

What is a correct description of the transformation?

- a translation to the right by 2 units and down by 2 units
- b translation to the right by 4 units and reflection about the horizontal axis
- c reflection about the horizontal axis followed by reflection about the vertical axis
- d translation to the right by 2 units and reflection about the horizontal axis

2. Lan Ying and Sean love bike riding. They take off from the same place, at the same time, going in the same direction.

Lan Ying rides at a steady speed of 6 km/h, and Sean rides at a steady speed of 4 km/h.

How far apart will they be in 3 hours?

- a 6 km
- b 12 km
- c 18 km
- d 30 km

3. Which set of values is represented by the 4 points on the number line?

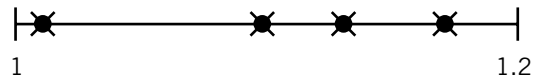

- a 1.05, 1.1, 1.5, 1.9
- b 1.01, 1.10, 1.13, 1.17
- c 1.1, 1.11, 1.15, 1.19
- d 1.01, 1.10, 1.12, 1.5,

4. Which pattern has this rule: decrease by subtracting the same amount from each term?

- a 20, 10, 5, 2.5, 1.25
- b 20, 18, 16, 14, 12
- c 20, 25, 30, 40, 45
- d 20, 40, 80, 160, 320

5. A circle is divided into sections of equal size.

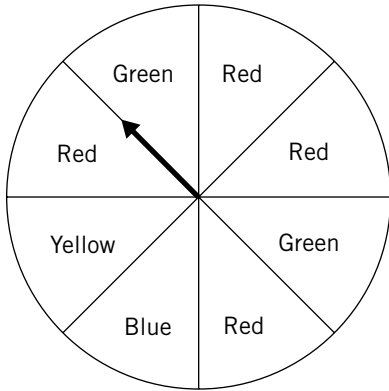

What is the probability that the spinner will stop on red?

- a 1 out of 4
  - b 3 out of 8
  - c 3 out of 4
  - d 1 out of 2
6. Write 207.083 in expanded form.
- a  $200 + 7 + 0.08 + 0.003$
  - b  $20 + 7 + 0.8 + 0.3$
  - c  $200 + 7 + 0.08 + 0.03$
  - d  $200 + 7 + 0.8 + 0.003$

7. Which triangle **must** have at least one  $60^\circ$  angle?

a

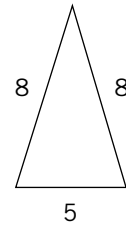

b

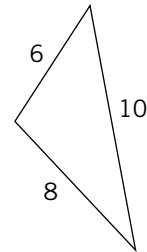

c

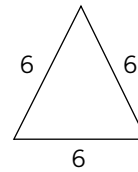

- d none of the above

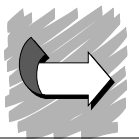



9. Sarah types 115 words in 5 minutes. Mary types 174 words in 8 minutes.

\* Who types faster?

Show your work.

\_\_\_\_\_ types faster.

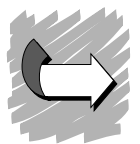

10. Jessica wants to pour 5 kg of sugar into smaller bags.

\* If each bag holds 250 grams, how many bags does she need?

Show your work.

Jessica needs \_\_\_\_\_ bags.

11. Jaspreet is wondering why she made the honour roll but her friend Cynthia did not. She knows that an overall percentage of 80 or higher makes the honour roll. She is not sure if the school uses the mean, median or mode to calculate the percentage.

Jaspreet's Marks

70 73 73 83 78 93 87 85 80

Cynthia's Marks

87 75 76 84 78 94 70 84 79

- \* Determine whether the school uses the mean, median or mode to calculate the overall percentage.

Show your work.

The school uses \_\_\_\_\_ to calculate the overall percentage.

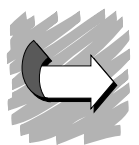

12. Follow the instructions below to create a polygon. You will need a protractor and a ruler. Start with the line BC below.
- 1) At Point B, use a protractor to create an angle of  $30^\circ$  with sides measuring 5 cm each.
  - 2) Label it  $\angle ABC$ .
  - 3) At Point C, create an angle of  $150^\circ$  and label it  $\angle BCD$ .
  - 4) Connect Point D to Point A with a 5 cm line to complete the polygon.

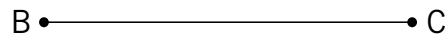

What is the name of this type of polygon? \_\_\_\_\_

13. Sharon works at the local gym. She must buy number stickers to label the lockers in the change rooms. Stickers are sold as individual digits. There are 79 lockers, which will be labelled 1 to 79.

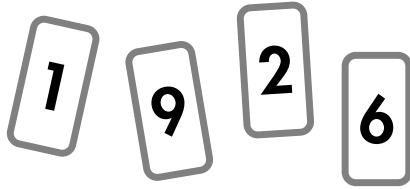

- \* How many stickers of each digit should she buy?

Show your work.

To label locker 19,  
Sharon buys two  
stickers:

1 and 9.

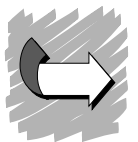

14. Look at the figures and table of values below.

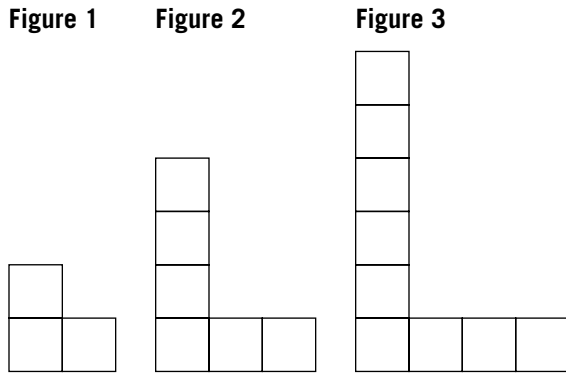

<b>Figure</b>	1	2	3	4	...	8	9
<b>Squares</b>	3	6	9	12	...	24	27
<b>Perimeter</b>	8	14	20	26	...	?	?

Which set of numbers represent the perimeter of the 8<sup>th</sup> and 9<sup>th</sup> figures?

- a 44, 50
- b 48, 54
- c 50, 56
- d 68, 76

15. Look at the figures.

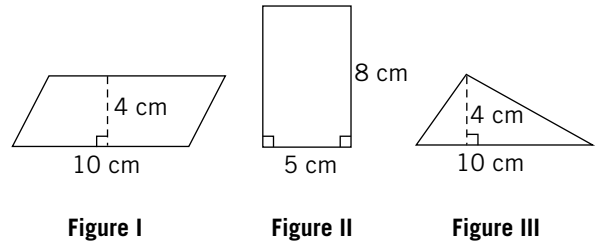

Which 2 figures have the same area?

- a Figure I and Figure II
- b Figure I and Figure III
- c Figure II and Figure III
- d none of the above

16. A rectangle is drawn on the first quadrant of a Cartesian grid as shown. The coordinates of Point B are given in the diagram below.

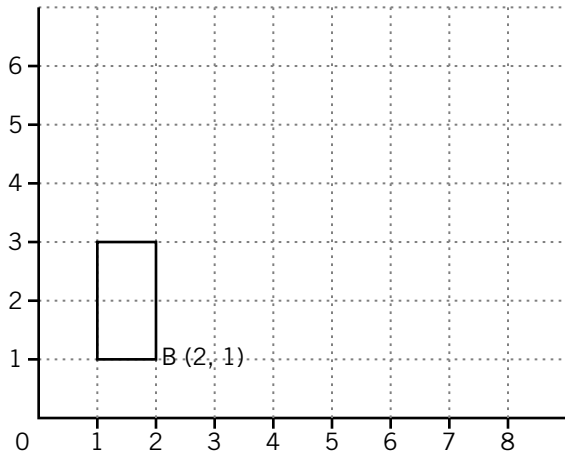

If the rectangle is translated 4 units to the right and 3 units up, the new coordinates of Point B will be

- a (3, 4)
- b (4, 3)
- c (5, 5)
- d (6, 4)

17. Nine towns, A to I, are spread out in a hilly region of the province. Their snowfall data for the past year are shown in a scatter plot.

What is the median annual snowfall for this group of towns?

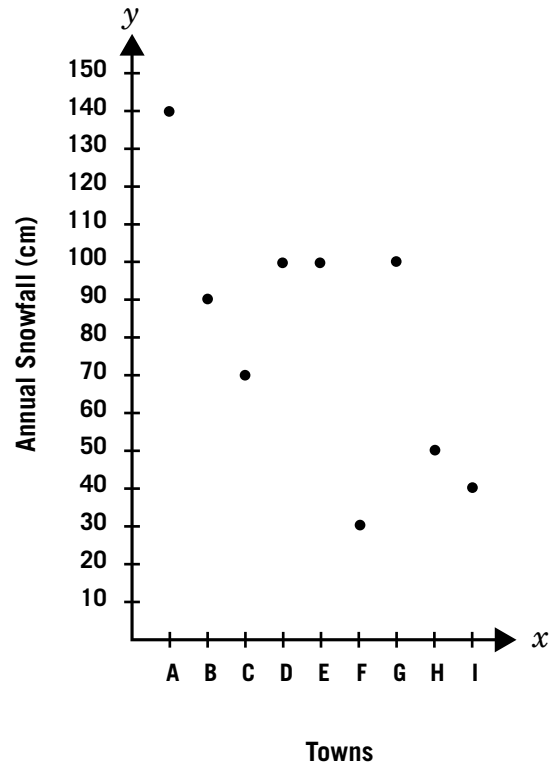

- a 80 cm
- b 85 cm
- c 90 cm
- d 100 cm

18. One of the numbers below meets the following conditions:
- It is a composite number.
  - It is between 22 and 32.
  - It has more than 4 factors.
  - It results in a prime number when its digits are added.

Which number is it?

- a 23
- b 25
- c 28
- d 30

19. If  $\square = 4$ , what is the value of  $21 - (4 \times \square)$ ?

- a 5
- b 13
- c 16
- d 68

20. Nicholas works on his math project for  $2\frac{1}{2}$  hours on Monday,  $1\frac{3}{4}$  hours on Wednesday and 3 hours on Thursday.

What is the total time he works on his math project, expressed in minutes?

- a 235 minutes
- b 360 minutes
- c 361 minutes
- d 435 minutes

21. A school requires students to participate in a team sport and play a musical instrument.

You are offered basketball and soccer as the team sports, and keyboard, drums and clarinet as the musical instruments.

Which diagram below shows all the possible choices for you?

a

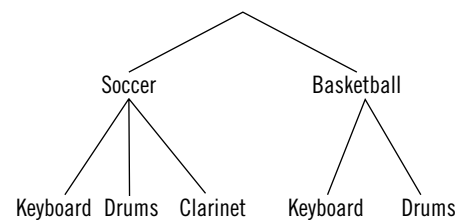

b

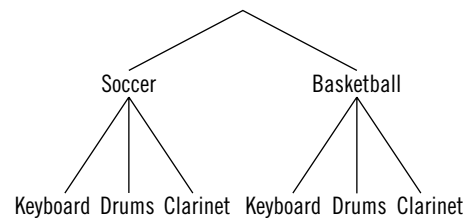

c

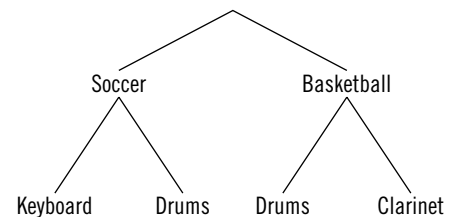

d

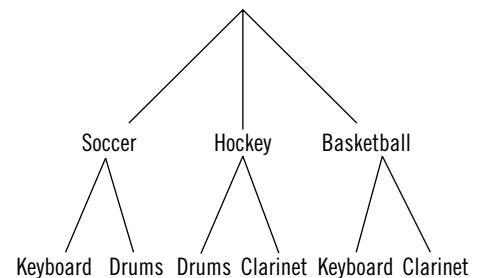

*Section*

**2**

22. Kevin's batting average this baseball season is 0.346. Last season his batting average was 0.297. How much higher is Kevin's batting average this season?

- a 0.049
- b 0.051
- c 0.059
- d 0.643

23. The pictograph below shows the number of students who chose different ice cream flavours as their favourite.

Favourite Ice Cream Flavours	
Vanilla	☺☺☺☺☺☺☺
Chocolate	☺☺☺☺☺☺☺☺☺
Strawberry	☺☺☺☺☺
Butterscotch	☺☺☺
Chocolate Chip	☺☺☺☺☺☺☺☺
Bubble Gum	☺☺☺☺☺

☺ represents 12 students

Which bar graph on the right best represents this data?

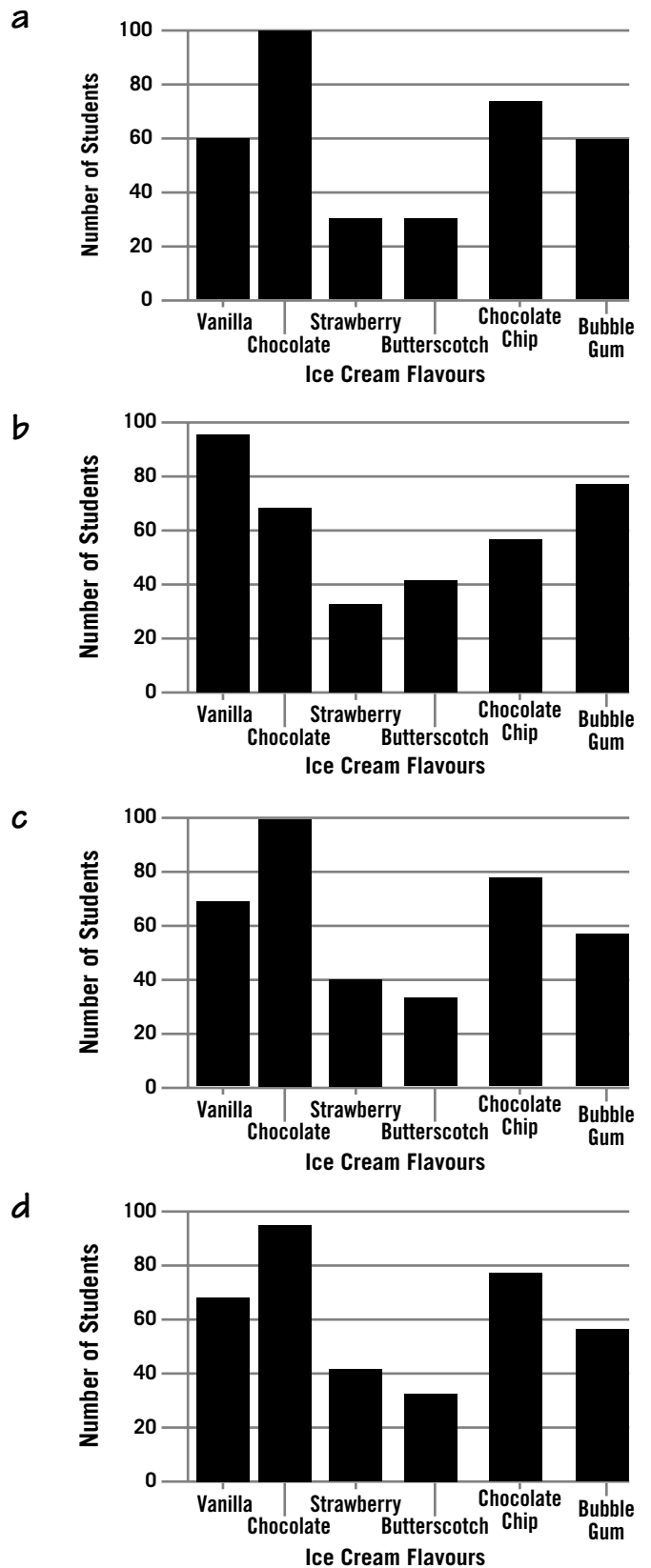

24. Which of the following is true of all three squares below?

May						
S	M	T	W	T	F	S
						1
2	3	4	5	6	7	8
9	10	11	12	13	14	15
16	17	18	19	20	21	22
23	24	25	26	27	28	29
30	31					

- a Subtract 8 from the top left number to get the bottom right number.
- b Add 8 to the top left number to get the bottom right number.
- c Add 7 to the top left number to get the bottom right number.
- d Subtract 7 from the top left number to get the bottom right number.

25. A watermelon has a mass of 2.4 kg. What is the mass expressed in g or mg?

- a 240 g or 240 000 mg
- b 2400 g or 2 400 000 mg
- c 2 400 000 g or 2400 mg
- d 0.0024 g or 0.000 002 4 mg

26. The closest estimate of the angle shown is

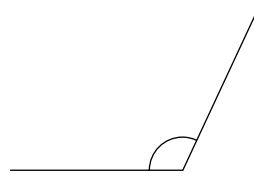

- a  $70^\circ$  to  $80^\circ$ .
- b  $85^\circ$  to  $95^\circ$ .
- c  $110^\circ$  to  $120^\circ$ .
- d  $140^\circ$  to  $150^\circ$ .

27. Simaya’s Grade 6 class has 25 students. The teacher tells her that this is 4% of the entire school’s student population.

How many students are in her school?

- a 100
- b 150
- c 600
- d 625

28. Which of the following descriptions is correct?

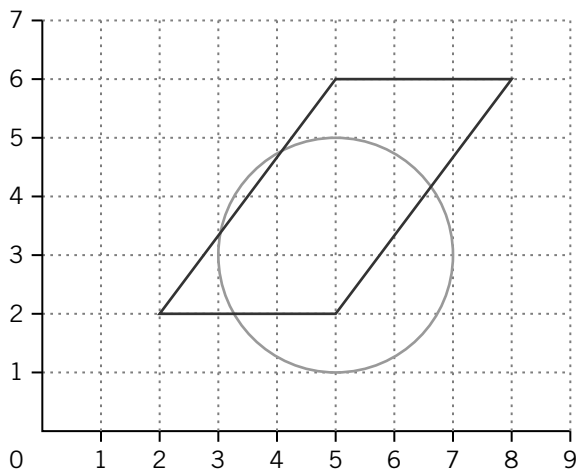

- a The point (6, 2) is outside the circle and outside the parallelogram.
- b The point (6, 2) is inside the circle and outside the parallelogram.
- c The point (6, 2) is outside the circle and inside the parallelogram.
- d The point (6, 2) is inside the circle and inside the parallelogram.

29. A number cube is tossed and a coin is flipped.

Using the tree diagram, determine which of the following events is most likely to occur.

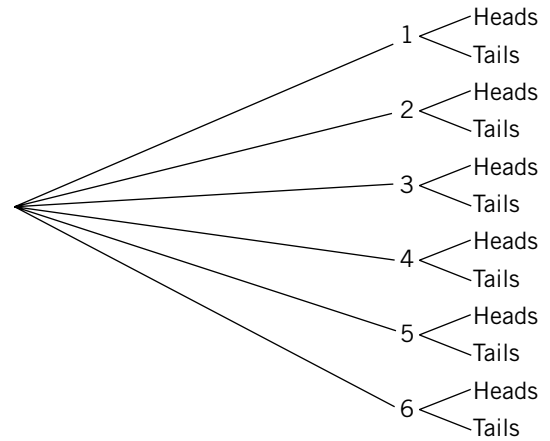

- a Tails appears on the coin.
- b Heads appears on the coin, and a 4 appears on the number cube.
- c A 3 appears on the number cube.
- d Heads appears on the coin, and a 3 appears on the number cube.

30. A department store's sales for one week are listed below.

<b>Clothing</b>	\$3240.00
<b>Cosmetics</b>	\$900.00
<b>Hardware</b>	\$2521.00
<b>Appliances</b>	\$583.00
<b>Other</b>	\$1011.00

\* Estimate the total sales for the week.

Explain your estimation strategy.

My estimate is \_\_\_\_\_.

31. Connor states that, for both diagrams, the shaded parts represent  $\frac{3}{8}$  of the whole figure.

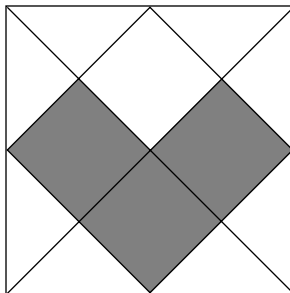
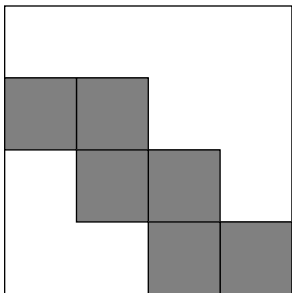

\* Is Connor correct?

Justify your answer.

**32.** Lindsay is cutting triangles to use in making some paper crafts. She notices that some of the triangles are exactly the same.

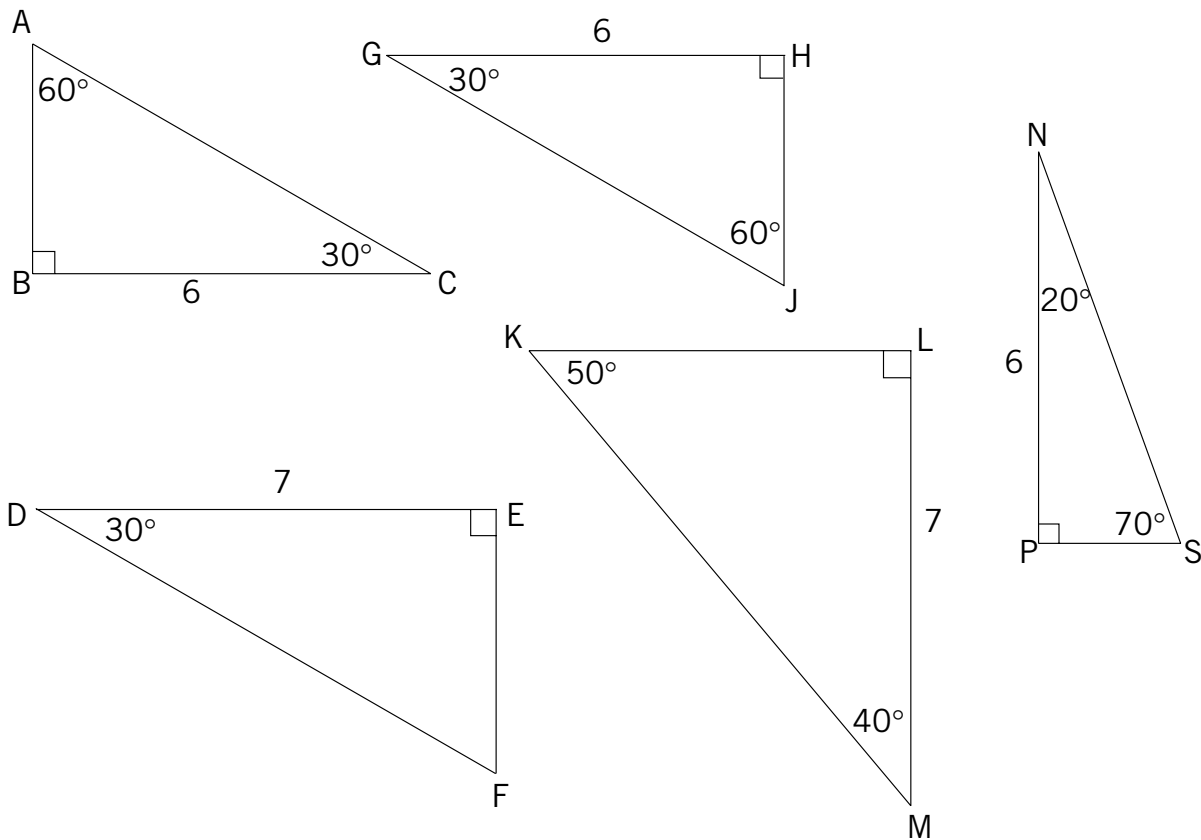

\* Find the congruent triangles.

Justify your answer.

**33.** A. J. notices a pattern in the vertical posts and horizontal boards in his fence. He counts the number of vertical posts, then subtracts one and multiplies by two to find the number of horizontal boards.

\* Fill in the table below to show the number of horizontal boards.

<b>Number of Vertical Posts</b>	<b>Number of Horizontal Boards</b>
2	
3	
4	
5	

34. Gary and Chris record the number of cars that pass their houses over 5 days. The results are shown below.

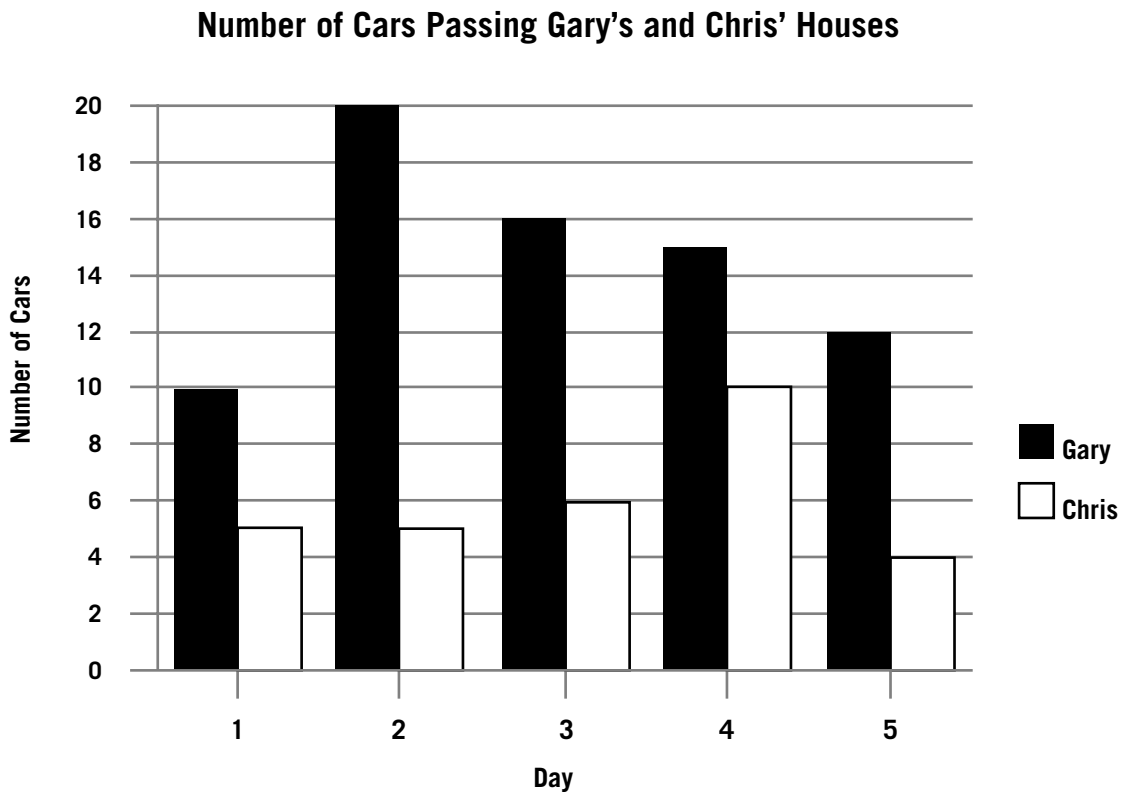

Gary says that each day the number of cars that pass his house is at least two times the number of cars that pass Chris' house.

Is Gary correct?

Explain your answer.

**35.** The triangle shown in the grid is rotated about point 0 by  $90^\circ$  in a clockwise direction.

What is its new position?

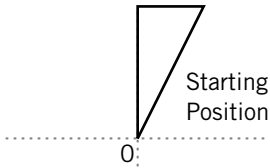

**a**

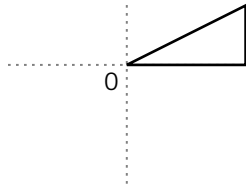

**b**

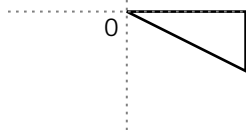

**c**

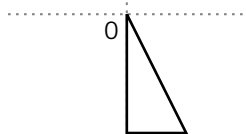

**d**

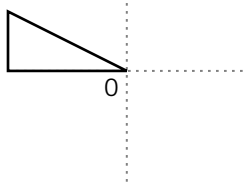

**36.** Andrew has \$20 in nickels. He gives \$3.75 to his sister and \$1.15 to his grandma and he spends \$0.65.

How many nickels does he have left?

- a** 237
- b** 289
- c** 14.45
- d** 0.7225

**37.**  $\frac{1}{1} + \frac{22}{22} + \frac{333}{333} = ?$

- a** 1
- b** 3
- c** 6
- d** 356

**38.** Smita types 5400 words per hour.

How many words does she type per minute?

- a** 1.5 words per minute
- b** 90 words per minute
- c** 60 words per minute
- d** 5400 words per minute

39. Which number best completes the pattern below?

2, 5, 11, 23, 47, 95, \_\_\_\_\_

- a 142
- b 190
- c 191
- d 192

40. Mark does a survey on favourite vegetables in his class. The graph represents the response data.

Student Votes for Favourite Vegetables

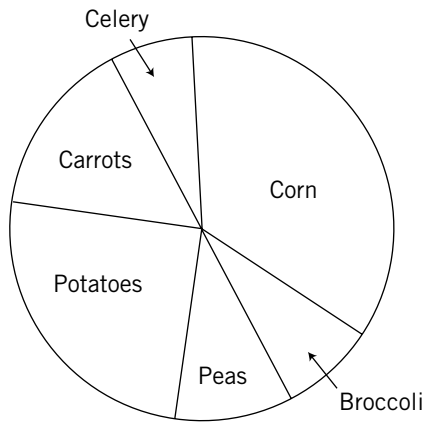

Which vegetable was chosen by about 25% of the class?

- a corn
- b peas
- c carrots
- d potatoes

41. What is the least common multiple for 6 and 10?

- a 20
- b 30
- c 40
- d 60

42. Alonzo's dad builds him a sandbox that measures 2.5 m long, 2 m wide and 0.5 m deep.

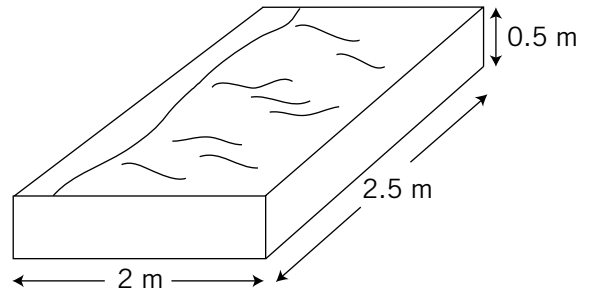

How much sand does Alonzo need to fill his sandbox to the top?

- a  $5 \text{ m}^3$
- b  $9 \text{ m}^3$
- c  $2.5 \text{ m}^3$
- d  $5.5 \text{ m}^3$

