

# Grade 3

Assessment of Reading, Writing and Mathematics, Primary Division

## Student Booklet

# Mathematics

SPRING 2009

**RELEASED ASSESSMENT QUESTIONS**

Education Quality and  
Accountability Office



Please note: The format of these booklets is slightly different from that used for the assessment. The items themselves remain the same.

**You may not use a calculator or manipulatives for questions 1–6.**

- 1** What are the missing numbers in the skip-counting pattern below?

800, 825, 850, 875, \_\_\_\_, \_\_\_\_, \_\_\_\_, 975

- 885, 895, 905
- 895, 900, 905
- 900, 925, 950
- 905, 930, 945

- 2** The school has 37 red skipping ropes and 45 blue skipping ropes.

Which number below is closest to the total number of skipping ropes the school has?

- 75
- 80
- 85
- 90

- 3** In which box can 6 be placed to make the equation true?

- $30 - 4 = 18 + \square$
- $30 - 4 = 19 + \square$
- $30 - 4 = 20 + \square$
- $30 - 4 = 21 + \square$

- 4** Susan and Danny are picking apples. Susan picks 274 apples and Danny picks 311.

How many more apples does Danny pick than Susan?

- 163
- 143
- 47
- 37

- 5** An increasing pattern is shown. What are the next four terms in the pattern?

1, 14, 27, 40, 53, \_\_\_\_, \_\_\_\_, \_\_\_\_, \_\_

- 66, 79, 92, 105
- 66, 80, 93, 107
- 67, 80, 93, 106
- 67, 82, 96, 111

**6** Marc receives \$5 a week for walking a dog.

He wants to buy a video game that costs \$42.

How many weeks will it take him to save enough money to buy the video game?

- 5
- 7
- 8
- 9

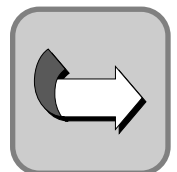

**You may now use  
a calculator and/or manipulatives.**

**7** Sally is making triangles using straws.

She creates a bar graph to show how many straws she needs to make triangles.

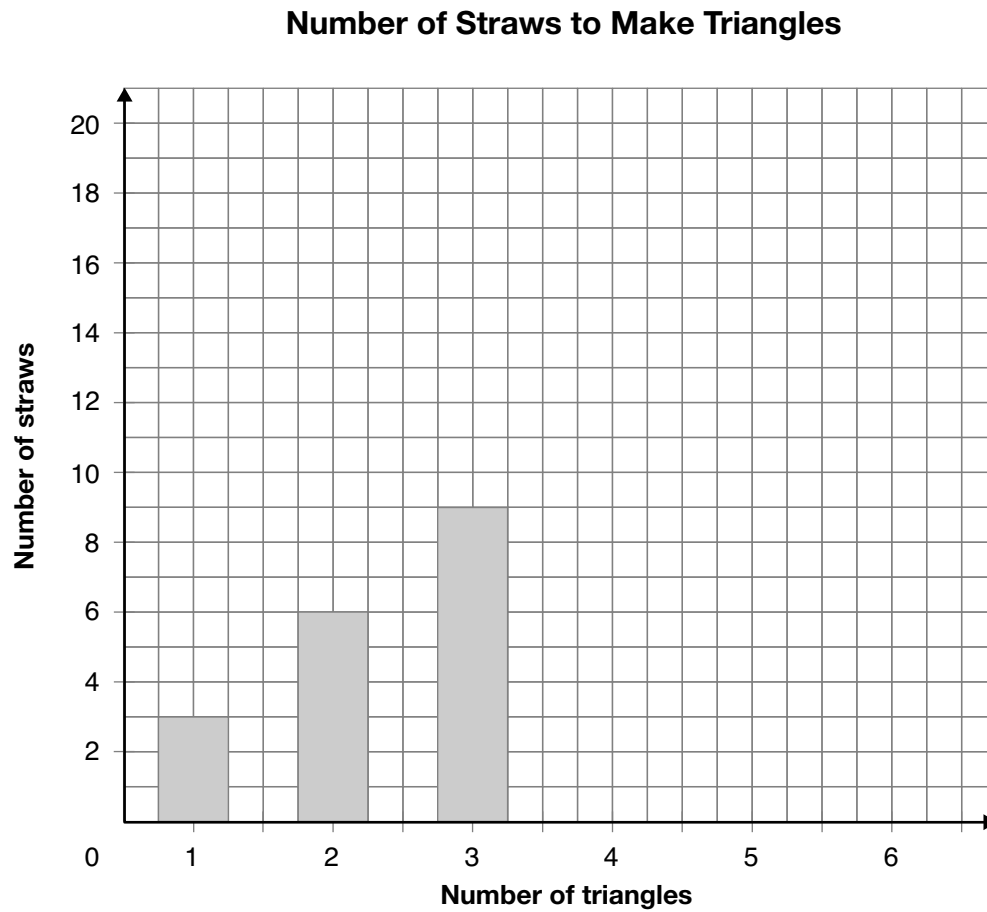

Complete the graph to show the number of straws for 4, 5 and 6 triangles.

How many straws will Sally need to make 8 triangles?

Justify your answer.

**8** Ethan saves 11 quarters.

He wants to buy a book that costs \$5.25.

How many more quarters does Ethan need to save to buy the book?

Justify your answer.

Ethan needs to save \_\_\_\_\_ more quarters.

- 9 Complete the shape on the grid so that it is symmetrical. Use the dashed line as a line of symmetry.

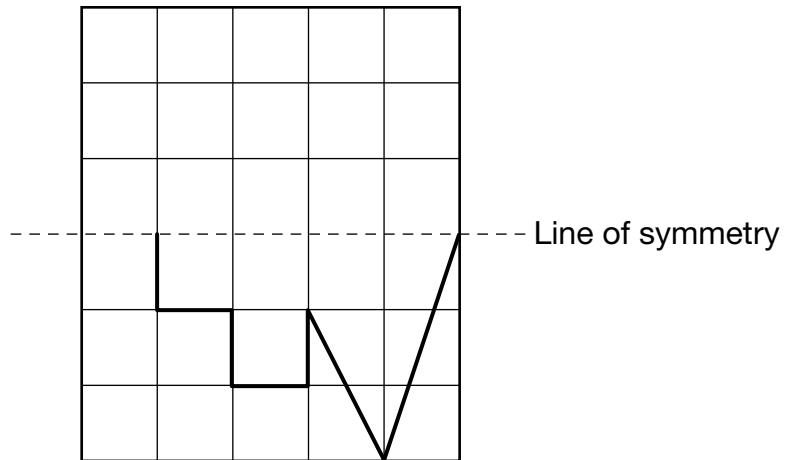

Explain how you know the completed shape is symmetrical.

**10** Look at the rectangles below.

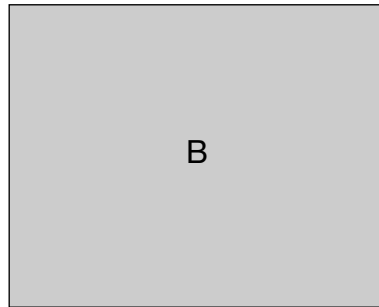
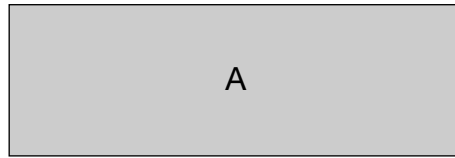

Which rectangle has the greater perimeter?

Justify your answer.

Rectangle \_\_\_\_\_ has the greater perimeter.

**11** Children are playing in the snow.  
Which is the most likely temperature outside?

- 32 °C
- 20 °C
- 12 °C
- 0 °C

**12** What number correctly completes the number sentence below?

$$\square \times 6 = 6$$

- 36
- 6
- 1
- 0

**13** Which clock shows the same time as the digital clock?

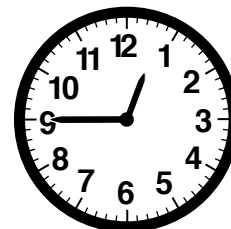
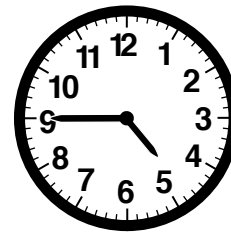
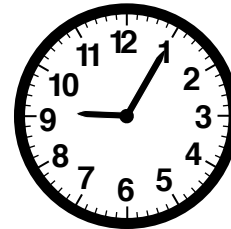
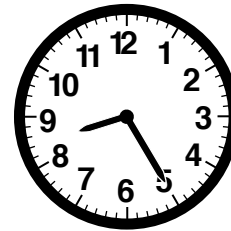

- 14** Kareem is playing a game using the spinner below.

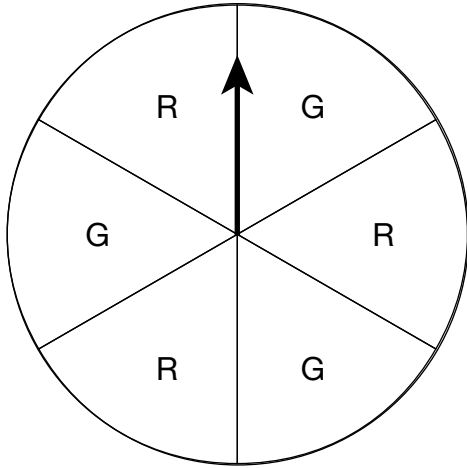

If the arrow lands on an R, Kareem wins.

How many times should Kareem expect to win if he spins the arrow 10 times?

- 3  
 5  
 6  
 10

- 15** Niveta makes a table to show how many books her friends have in their desks.

**Books**

Name	Number of books
Jana	6
Kwabena	5
Preet	7
Luke	5
Leah	6
Gurbir	4
Angelo	5



What is the mode of Niveta's data?

- 4  
 5  
 6  
 7





- 16** How many days are in 4 weeks?

- 7  
 14  
 28  
 30

17 Look at the table below.

Mass of Objects	
Object	Mass
 <b>Book</b>	one kg
 <b>Bag of marbles</b>	one-quarter kg
 <b>Bananas</b>	one-half kg

Which of the following shows the objects in order from lightest to heaviest?

- 
- 
- 
- 

18 Which number is equal to 7 hundreds, 13 tens and 6 ones?

- 637
- 736
- 836
- 7136

- 19** Sheni makes a pattern around the edge of her art folder.

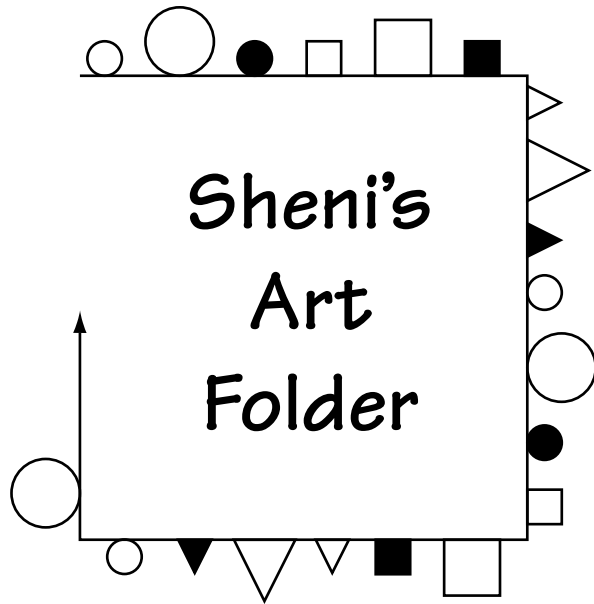

What are the next 3 shapes in Sheni's pattern?

- □ □
- ▲ ○ ○
- ○ ●
- □ ●





- 20** Joseph adds  $63 + 17$  in his head. Which of the following will give Joseph the same answer?

- $60 + 10 + 7$
- $60 + 20 + 10$
- $60 + 10 + 7 + 3$
- $60 + 10 + 10 + 3$

- 21** Samir spends \$7.25 at the store. How much change should he receive from \$10.00?

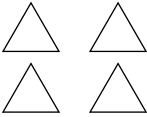
- \$2.25
- \$2.75
- \$3.25
- \$3.75

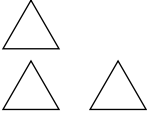
22 The chart below shows information about the faces of some pyramids.

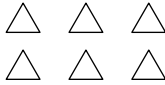
Pyramids		
Name	Base	Remaining sides
Square-based		
Triangular-based		
_____		

What pyramid name is missing from the chart?

- octagonal-based
- hexagonal-based
- pentagonal-based
- rectangular-based

23 Look at the letters below. Count the lines of symmetry each letter has.

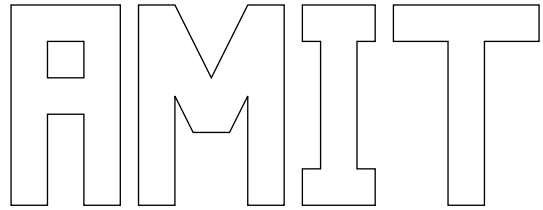

How many lines of symmetry are there in total?

- 3
- 4
- 5
- 6

**24** Mrs. Moore's class records the outside temperature each morning for a week. On Wednesday, they record the temperature as  $15^{\circ}\text{C}$ . On Thursday, the temperature is 4 degrees cooler. Which thermometer matches the temperature reading for Thursday?

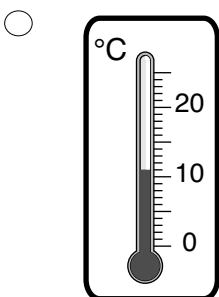
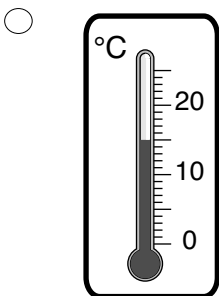
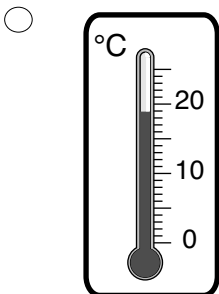
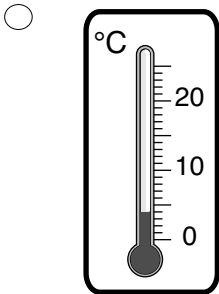

**25** Which of the following lists the measurements in order from longest to shortest?

- 90 cm; 1 m 34 cm; 223 cm
- 223 cm; 1 m 34 cm; 90 cm
- 223 cm; 90 cm; 1 m 34 cm
- 1 m 34 cm; 90 cm; 223 cm

**26** Alexandra has 12 tiles in a bag. The tiles are red, blue or green. How many tiles of each colour should be in the bag to make all colours equally likely to be drawn?

- 1
- 3
- 4
- 12

27 Jocelyn surveys all the Grade 3 students about their favourite colour.

Her results are shown in the table below.

**Favourite Colour**

Colour	Number of students
Red	24
Blue	16
Green	8
Yellow	11

Create a bar graph showing this data. Remember to include all titles and labels.

Your graph must fit on the grid below.

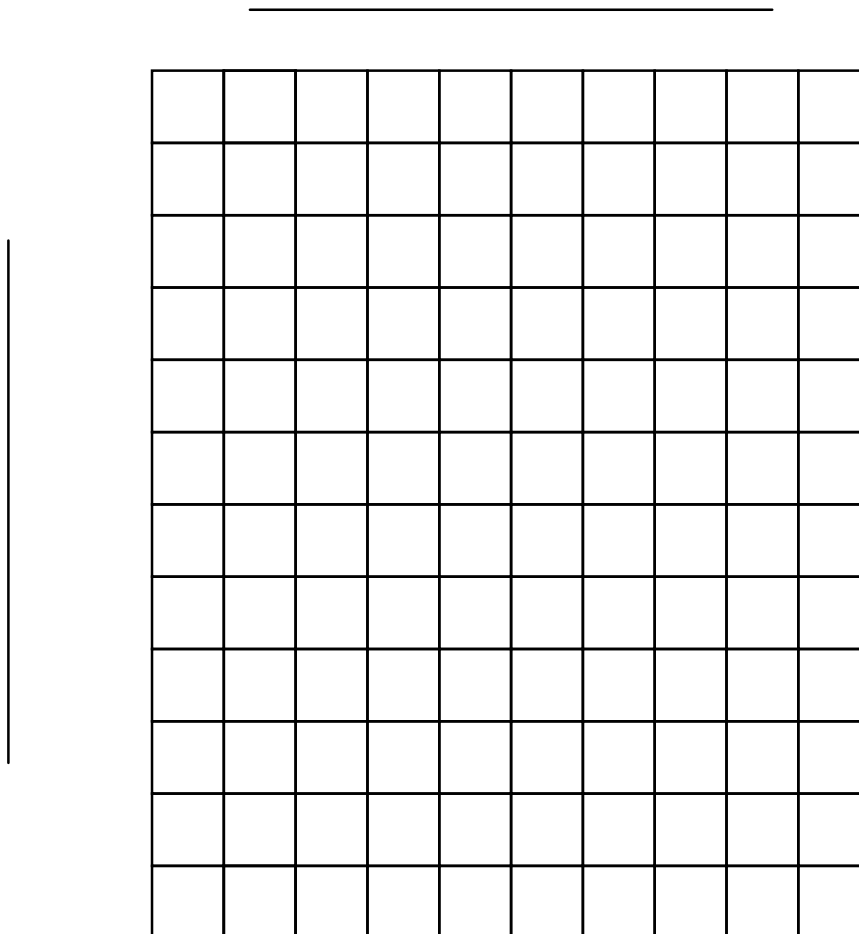

- 28** A Grade 3 class wins a pizza party for reading the most books in September. There are 23 students in the class and each student will get 2 slices of pizza. If each pizza has 6 slices, how many pizzas should the class buy?

Show your work.

The class should buy \_\_\_\_\_ pizzas.

29 Dale plays at the park each day after school.

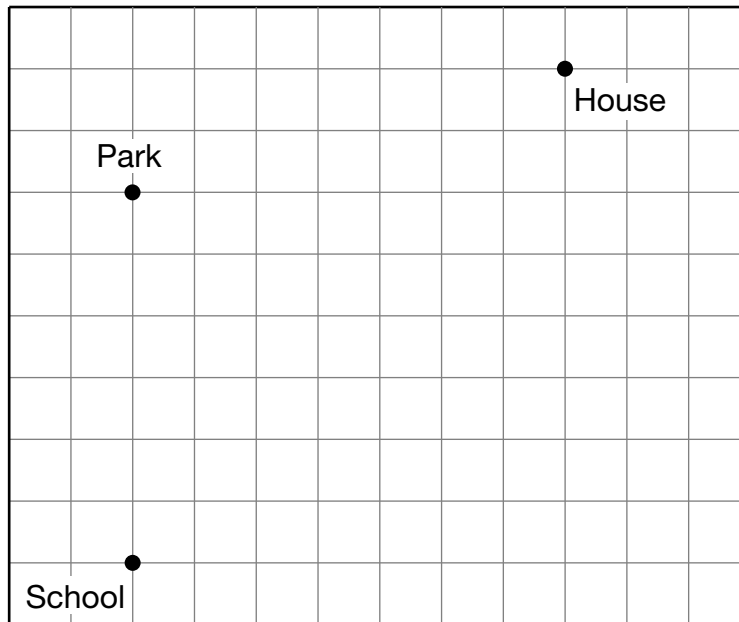

He walks only on the grid lines. Draw the shortest path he can take from the school to the park and then to his house.

Describe Dale's path.

- 30** In a class, 26 students choose their favourite type of animal. Their answers are shown in the pictograph below.

**Favourite Type of Animal**

<b>Cat</b>	<input type="checkbox"/> <input type="checkbox"/> <input type="checkbox"/>
<b>Bird</b>	<input type="checkbox"/> <input type="checkbox"/> <input type="checkbox"/> <input type="checkbox"/> <input type="checkbox"/>
<b>Dog</b>	
<b>Other</b>	<input type="checkbox"/> <input type="checkbox"/>

<b>Key</b>	
Each <input type="checkbox"/>	represents 2 students.

The pictograph is missing the information for dogs.

Complete the pictograph to show how many students choose dogs.

Justify your answer.

**31** What is the area of this shape?

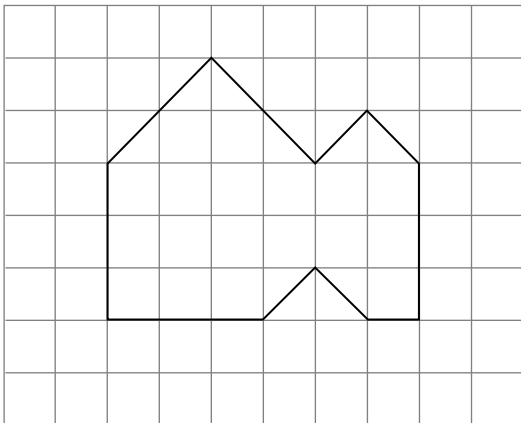

- 18 square units
- 20 square units
- 22 square units
- 26 square units

**32** Which number sentence describes the drawing below?

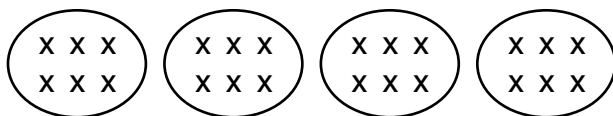

- $1 \times 24 = 24$
- $2 \times 12 = 24$
- $4 \times 6 = 24$
- $8 \times 3 = 24$

**33** What number can be placed in both boxes to make the following expressions have the same value?

$$\square \times 7$$

$$\square \times 6$$

- 7
- 6
- 1
- 0

**34** Karen draws the picture below using 2-D shapes.

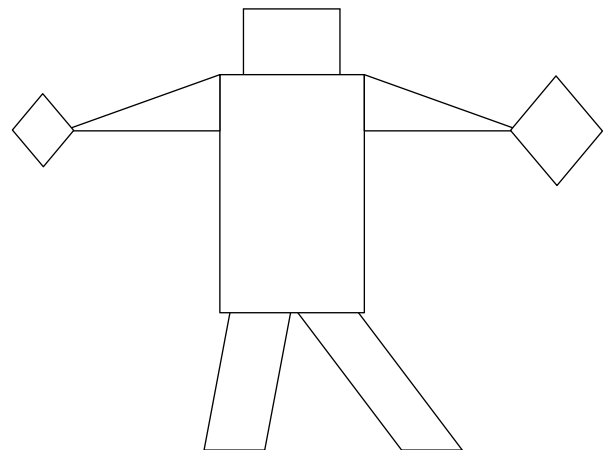

Which shapes are congruent in her picture?

- triangles
- rectangles
- rhombuses
- parallelograms

**35** Using the green triangle, find the total area of these pattern blocks.

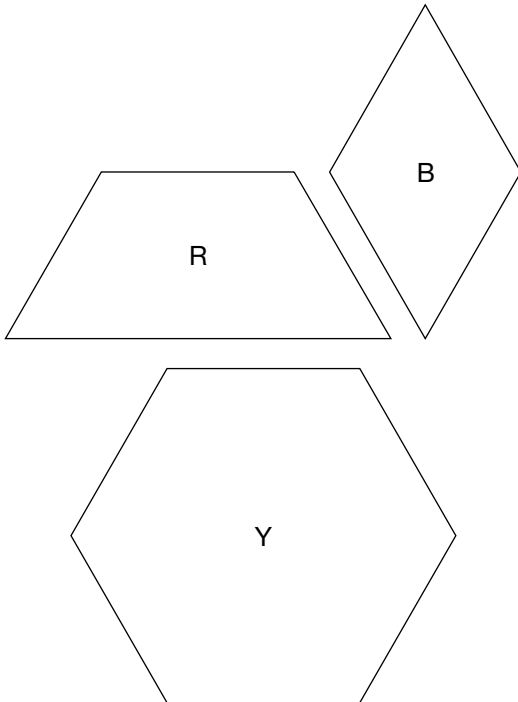
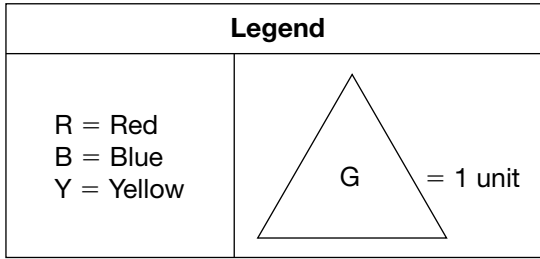

What is the total area of all 3 pattern blocks?

- 9 units
- 10 units
- 11 units
- 12 units

**36** Which figure below has the same number of vertices and faces?

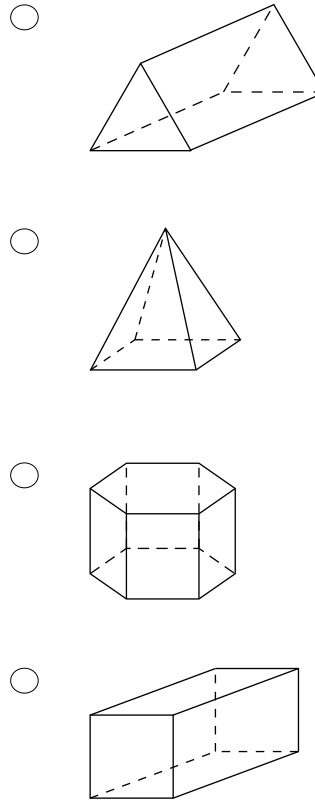

**Education Quality and  
Accountability Office**



2 Carlton Street, Suite 1200, Toronto ON M5B 2M9

Telephone: 1-888-327-7377 Web site: [www.eqao.com](http://www.eqao.com)

© 2009 Queen's Printer for Ontario