

Education Quality and
Accountability Office



Grade 9 Assessment of Mathematics
Spring 2008, Academic

**Released Item-Specific Rubrics and
Sample Student Responses with
Annotations**

What Side? (Spring 2008)

Code	Descriptor
B	Blank: nothing written or drawn in response to the question
I	<ul style="list-style-type: none"> - Illegible: cannot be read; completely crossed out/erased; not written in English; - Irrelevant content: does not attempt assigned question (e.g., comment on the task, drawings, “?”, “!”, “I don’t know”); - Off topic: no relationship of written work to the question.
10	<p>Application of knowledge and skills of rearranging a formula to determine the measures of each side of the triangle shows limited effectiveness due to</p> <ul style="list-style-type: none"> • misunderstanding of concepts; • incorrect selection or misuse of procedures.
20	<p>Application of knowledge and skills of rearranging a formula to determine the measures of each side of the triangle shows some effectiveness due to</p> <ul style="list-style-type: none"> • partial understanding of the concepts; • errors and/or omissions in the application of the procedures.
30	<p>Application of knowledge and skills of rearranging a formula to determine the measures of each side of the triangle shows considerable effectiveness due to</p> <ul style="list-style-type: none"> • an understanding of most of the concepts; • minor errors and/or omissions in the application of the procedures.
40	<p>Application of knowledge and skills of rearranging a formula to determine the measures of each side of the triangle shows a high degree of effectiveness due to</p> <ul style="list-style-type: none"> • a thorough understanding of the concepts; • an accurate application of the procedures (any minor errors and/or omissions do not detract from the demonstration of a thorough understanding) <p>(e.g., $x = 11$, sides are 13 m, 25 m, 37 m)</p>

The perimeter of the triangle below is 75 m.

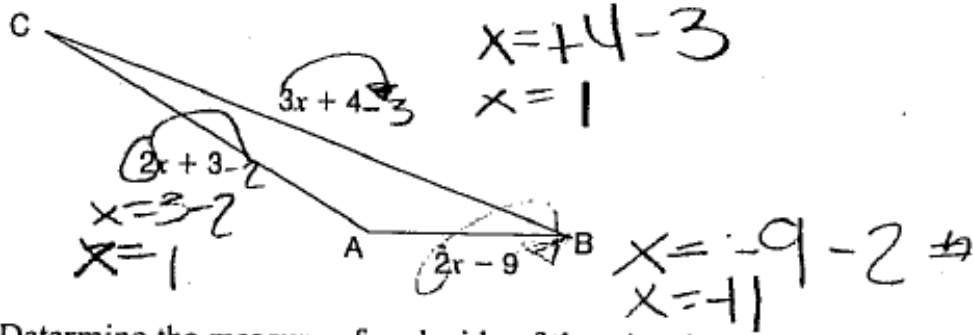

Determine the measure of each side of the triangle.

Show your work.

$$\begin{aligned} CB &= 7 & ? \\ AB &= -31 & ? \\ AC &= 5 & \end{aligned}$$

Annotation:

Student demonstrates a misunderstanding of the concepts; misunderstanding that x can be two different values and no expression determined for the perimeter.

The perimeter of the triangle below is 75 m.

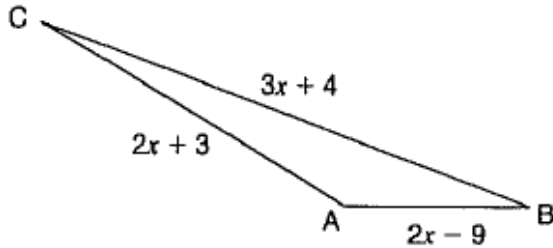

Determine the measure of each side of the triangle.

Show your work.

$$2x + 3 + 3x + 4 + 2x - 9 = 75$$

$$5x + 7x + 2x - 9 = 75$$

$$12x + 2x - 9 = 75$$

$$14x - 9 = 75$$

$$5x = \frac{75}{5}$$

$$x = 15$$

$$CA = 33$$

$$CB = 49$$

$$AB = 21$$

Annotation:

Student demonstrates errors in the application of the procedures; sets up correct equation, algebraic errors adding and subtracting like terms, but measure of each side determined correctly using $x = 15$.

The perimeter of the triangle below is 75 m.

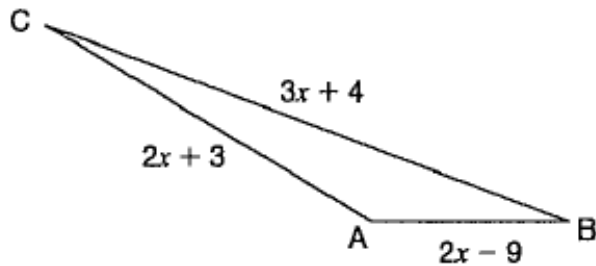

Determine the measure of each side of the triangle.

Show your work.

$$3x + 4 + 2x + 3 + 2x - 9$$

$$= 7x - 2 = 75$$

$$= \frac{7x}{7} = \frac{73}{7}$$

$$= x = 10.43$$

$$\begin{array}{l} \underline{CB} \\ 3x + 4 \\ = 3(10.4) + 4 \\ = 35.2 \end{array}$$

$$\begin{array}{l} \underline{CA} \\ 2x + 3 \\ = 2(10.4) + 3 \\ = 23.8 \end{array}$$

$$\begin{array}{l} \underline{AB} \\ 2x - 9 \\ = 2(10.4) - 9 \\ = 11.8 \end{array}$$

Annotation:

Student demonstrates minor errors in the application of the procedures; subtracts 2 from each side of equation when solving for x , rounds x value to 10.4 and determines the measures of the sides accurately using 10.4.

The perimeter of the triangle below is 75 m.

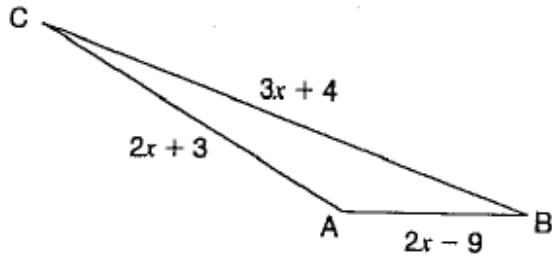

Determine the measure of each side of the triangle.

Show your work.

$$75 = (2x + 3) + (3x + 4) + (2x - 9)$$

$$75 = 7x - 2$$

$$\frac{77}{7} = \frac{7x}{7}$$

$$11 = x$$

$$\begin{aligned} s_{AB} &= 2 \times 11 - 9 \\ s_{BC} &= 3 \times 11 + 4 \\ s_{CA} &= 2 \times 11 + 3 \end{aligned}$$

$$22 + 3 + 33 + 4 + 22 - 9$$

$$25 + 37 + 13$$

$$25 + 50$$

$$75$$

Annotation:

Student demonstrates a thorough understanding of the concepts; accurate work shown to determine $x = 11$, correctly calculates the measures of the sides and verifies that these values result in a perimeter of 75 m.

Assessment of Mathematics
 Grade 9 Academic Program
 Specific Open-Response Scoring Guide
Wing Length (Spring 2008)

Code	Descriptor
B	Blank: nothing written or drawn in response to the question
I	<ul style="list-style-type: none"> - Illegible: cannot be read; completely crossed out/erased; not written in English; - Irrelevant content: does not attempt assigned question (e.g., comment on the task, drawings, “?”, “!”, “I don’t know”); - Off topic: no relationship of written work to the question.
10	<p>Problem-solving process to determine the age of the bird shows limited effectiveness due to</p> <ul style="list-style-type: none"> • minimal evidence of a solution process; • limited identification of important elements of the problem; • too much emphasis on unimportant elements of the problem; • no conclusions presented or conclusion presented without supporting evidence.
20	<p>Problem-solving process to determine the age of the bird shows some effectiveness due to</p> <ul style="list-style-type: none"> • an incomplete solution process; • identification of some of the important elements of the problem; • some understanding of the relationships between important elements of the problem; • simple conclusions with little supporting evidence.
30	<p>Problem-solving process to determine the age of the bird shows considerable effectiveness due to</p> <ul style="list-style-type: none"> • a solution process that is nearly complete; • identification of most of the important elements of the problem; • a considerable understanding of the relationships between important elements of the problem; • appropriate conclusions with supporting evidence.
40	<p>Problem-solving process to determine the age of the bird shows a high degree of effectiveness due to</p> <ul style="list-style-type: none"> • a complete solution process; • identification of all important elements of the problem; • a thorough understanding of the relationships between all of the important elements of the problem; • appropriate conclusions with thorough and insightful supporting evidence.

Wing length is a reliable method for determining the age of young birds. Below is an example of data for a particular species.

Wing length (cm)	Age (days)
1.5	4
3.1	8
3.2	10
4.1	12
5.2	16

Determine the age of a bird with a wing length of 3.6 cm.

You may use the grid if you wish.

Justify your answer.

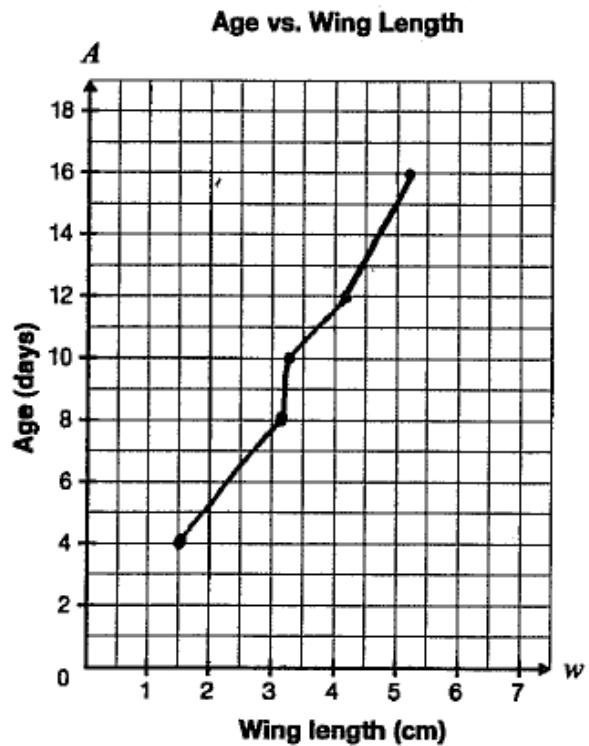

Annotation:

Problem solving process demonstrates minimal evidence of a solution process; conclusion missing but points plotted and joined with no attempt at a solution using a line of best fit or an algebraic solution.

Wing length is a reliable method for determining the age of young birds. Below is an example of data for a particular species.

Wing length (cm)	Age (days)
1.5	4
3.1	8
3.2	10
4.1	12
5.2	16

Determine the age of a bird with a wing length of 3.6 cm.

You may use the grid if you wish.

Justify your answer.

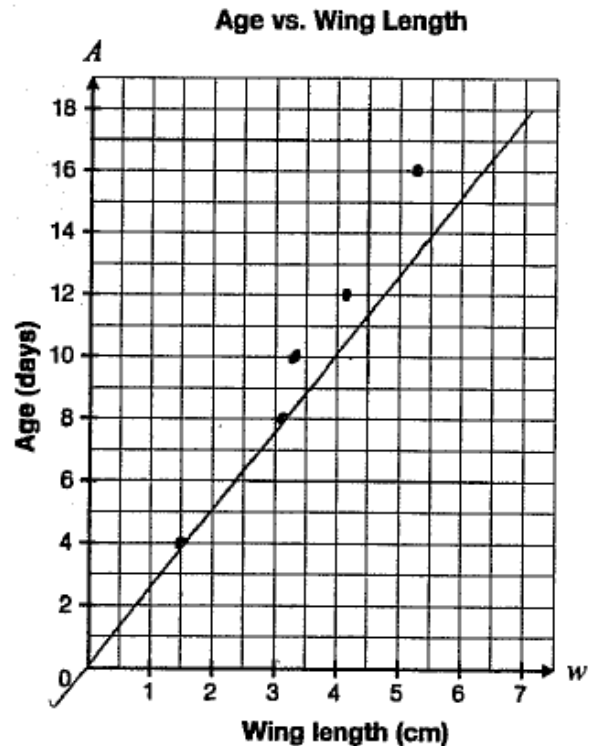

Annotation:

Problem solving process demonstrates an incomplete solution process; points plotted correctly and solution started by drawing a line of best fit appropriately with no attempt at interpolation and conclusion missing.

Wing length is a reliable method for determining the age of young birds. Below is an example of data for a particular species.

Wing length (cm)	Age (days)
1.5	4
3.1	8
3.2	10
4.1	12
5.2	16

x average = 3.42
 y average = 10

Determine the age of a bird with a wing length of 3.6 cm.

You may use the grid if you wish.

Justify your answer.

$$m = \frac{3}{2} \quad b = 0$$

$$y = \frac{3}{2}x$$

$$y = \frac{3}{2}(3.6)$$

$$y = 5.4$$

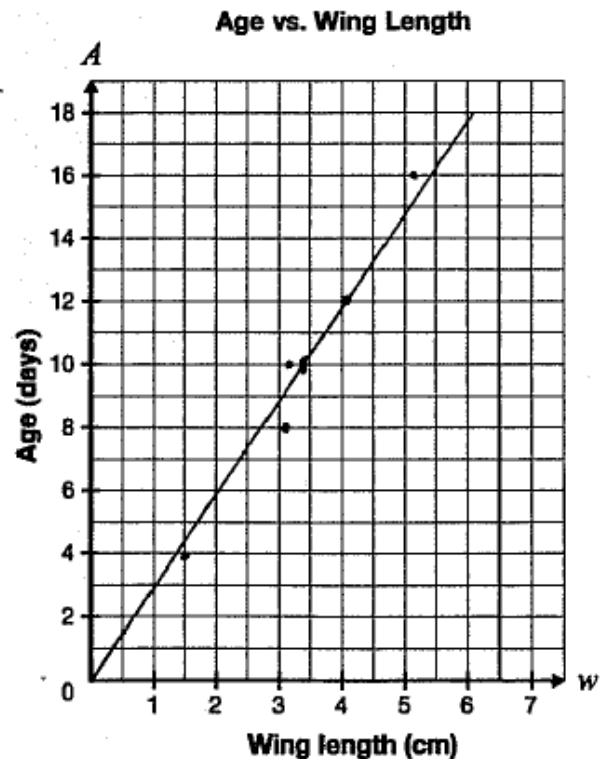

Annotation:

Problem solving process demonstrates a considerable understanding of the relationship between important elements of the problem; appropriate algebraic method used to determine the age of the bird and line of best fit drawn to justify equation and show overall trend considered, but misreads scale when calculating slope.

Wing length is a reliable method for determining the age of young birds. Below is an example of data for a particular species.

Wing length (cm)	Age (days)
1.5	4
3.1	8
3.2	10
4.1	12
5.2	16

Determine the age of a bird with a wing length of 3.6 cm.

- You may use the grid if you wish.

Justify your answer.

A bird with a wing length of 3.6 is about 11 days old.

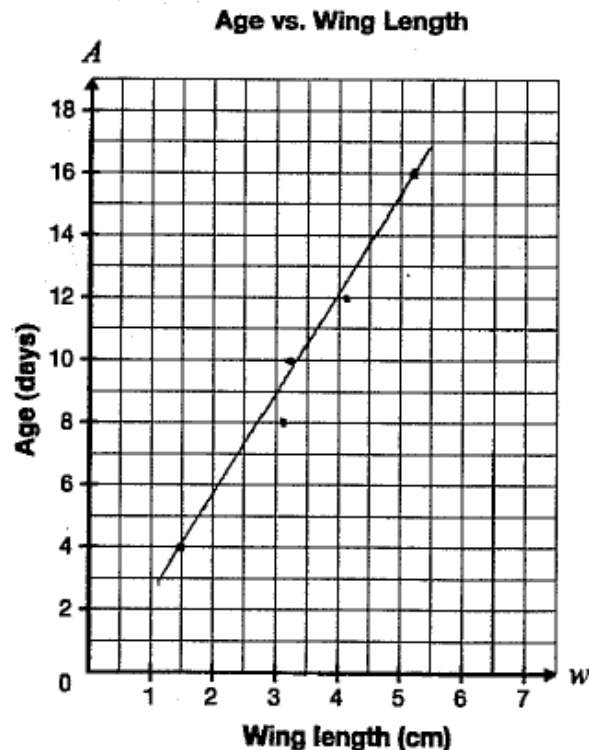

Annotation:

Problem solving process demonstrates a complete solution process; points plotted and appropriate method used (interpolation) as line of best fit is drawn and it justifies interpolation of 3.6 cm at 11 days even though a point is not evident at that place on the line.

Excellent Equations (Spring 2008)

Code	Descriptor
B	Blank: nothing written or drawn in response to the question
I	<ul style="list-style-type: none"> - Illegible: cannot be read; completely crossed out/erased; not written in English; - Irrelevant content: does not attempt assigned question (e.g., comment on the task, drawings, “?”, “!”, “I don’t know”); - Off topic: no relationship of written work to the question.
10	<p>Problem-solving process to determine the equation of a line shows limited effectiveness due to</p> <ul style="list-style-type: none"> • minimal evidence of a solution process; • limited identification of important elements of the problem; • too much emphasis on unimportant elements of the problem; • no conclusions presented or conclusion presented without supporting evidence.
20	<p>Problem-solving process to determine the equation of a line shows some effectiveness due to</p> <ul style="list-style-type: none"> • an incomplete solution process; • identification of some of the important elements of the problem; • some understanding of the relationships between important elements of the problem; • simple conclusions with little supporting evidence.
30	<p>Problem-solving process to determine the equation of a line shows considerable effectiveness due to</p> <ul style="list-style-type: none"> • a solution process that is nearly complete; • identification of most of the important elements of the problem; • a considerable understanding of the relationships between important elements of the problem; • appropriate conclusions with supporting evidence.
40	<p>Problem-solving process to determine the equation of a line shows a high degree of effectiveness due to</p> <ul style="list-style-type: none"> • a complete solution process; • identification of all important elements of the problem; • a thorough understanding of the relationships between all of the important elements of the problem; • appropriate conclusions with thorough and insightful supporting evidence.

A line is perpendicular to the line $y = 2x + 3$ and has the same x -intercept as $x + 3y + 10 = 0$.

Find the equation of this line. Express your answer in the form $y = mx + b$.

Justify your answer.

$y = 2x + -1$
because the line is perpendicular
with the line $y = 2x + 3$.

Annotation:

Problem solving process demonstrates limited identification of important elements of the problem; student creates an equation and uses -1 as the y -intercept but references perpendicularity.

A line is perpendicular to the line $y = 2x + 3$ and has the same x -intercept as $x + 3y + 10 = 0$.

Find the equation of this line. Express your answer in the form $y = mx + b$.

Justify your answer.

$$\begin{aligned}y = 0: x + 3y + 10 &= 0 \\x + 3(0) + 10 &= 0 \\x + 10 - 10 &= 0 - 10 \\x &= -10\end{aligned}$$

$$x = -10$$

Annotation:

Problem solving process demonstrates incomplete solution and identification of some of the important elements of the problem; student determines the x -intercept with justification, does not determine slope or new equation of the new line.

A line is perpendicular to the line $y = 2x + 3$ and has the same x -intercept as $x + 3y + 10 = 0$.

Find the equation of this line. Express your answer in the form $y = mx + b$.

Justify your answer.

$$\begin{array}{l} \underline{x\text{-int}} \\ x + 3y + 10 = 0 \\ x + 10 = 0 \\ x = -10 \\ \therefore \text{The point is } (-10, 0) \end{array} \quad \left| \quad \begin{array}{l} y = 2x + 3 \\ \therefore \text{The slope is } 2 \end{array} \right.$$

$\therefore x + 3y + 10 = 0$ has the same x -int as $y = 2x + 3$ and the slope is 2.

Subst $(-10, 0)$ into x, y and the slope.

$$\begin{array}{l} y = mx + b \\ 0 = 2(-10) + b \\ 0 = -20 + b \\ 20 = b \end{array}$$

$\therefore y = 2x + 20$ is the req'd eqⁿ for this question.

Annotation:

Problem solving process demonstrates a solution process that is nearly complete; omits determining slope of a perpendicular line, uses slope of line given, process correct in determining x -intercept of given line and y -intercept of new line using incorrect slope.

A line is perpendicular to the line $y = 2x + 3$ and has the same x -intercept as $x + 3y + 10 = 0$.

Find the equation of this line. Express your answer in the form $y = mx + b$.

Justify your answer.

$$y = 2x + 3$$

$\Rightarrow m = 2$
because perpendicular, so

$$m_1 \times m_2 = -1$$

$$m = -\frac{1}{2}$$

$$x + 3y + 10 = 0$$

$$x = -3y - 10$$

\therefore the x -intercept is -10 .

use the slope $m = -\frac{1}{2}$

\therefore y -intercept $= -5$

\therefore The final equation is

$$y = -\frac{1}{2}x - 5$$

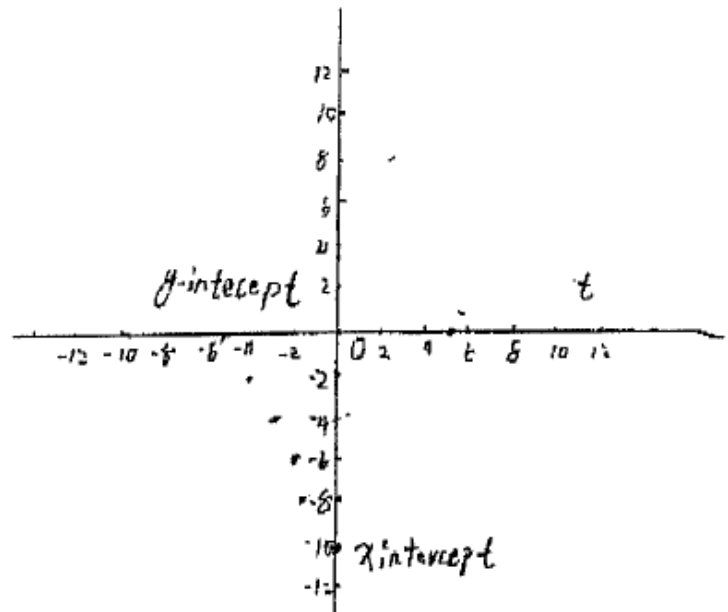

Annotation:

Problem solving process demonstrates identification of all of the important elements of the problem; the process is well described and justified, ignore labeling of graph, method of determining the y -intercept by using the slope to move from the x -intercept to the y -intercept is acceptable.

Wheels of Fun (Spring 2008)

Code	Descriptor
B	Blank: nothing written or drawn in response to the question
I	<ul style="list-style-type: none"> - Illegible: cannot be read; completely crossed out/erased; not written in English; - Irrelevant content: does not attempt assigned question (e.g., comment on the task, drawings, “?”, “!”, “I don’t know”); - Off topic: no relationship of written work to the question.
10	<p>Problem-solving process to determine the values of x and y shows limited effectiveness due to</p> <ul style="list-style-type: none"> • minimal evidence of a solution process; • limited identification of important elements of the problem; • too much emphasis on unimportant elements of the problem; • no conclusions presented or conclusion presented without supporting evidence.
20	<p>Problem-solving process to determine the values of x and y shows some effectiveness due to</p> <ul style="list-style-type: none"> • an incomplete solution process; • identification of some of the important elements of the problem; • some understanding of the relationships between important elements of the problem; • simple conclusions with little supporting evidence.
30	<p>Problem-solving process to determine the values of x and y shows considerable effectiveness due to</p> <ul style="list-style-type: none"> • a solution process that is nearly complete; • identification of most of the important elements of the problem; • a considerable understanding of the relationships between important elements of the problem; • appropriate conclusions with supporting evidence.
40	<p>Problem-solving process to determine the values of x and y shows a high degree of effectiveness due to</p> <ul style="list-style-type: none"> • a complete solution process; • identification of all important elements of the problem; • a thorough understanding of the relationships between all of the important elements of the problem; • appropriate conclusions with thorough and insightful supporting evidence. <p>(e.g., $x = 80^\circ$ and $y = 160^\circ$)</p>

A Ferris wheel has six sides of equal length. The exit ramp of the Ferris wheel is in the shape of a trapezoid and has an angle of incline of 20° .

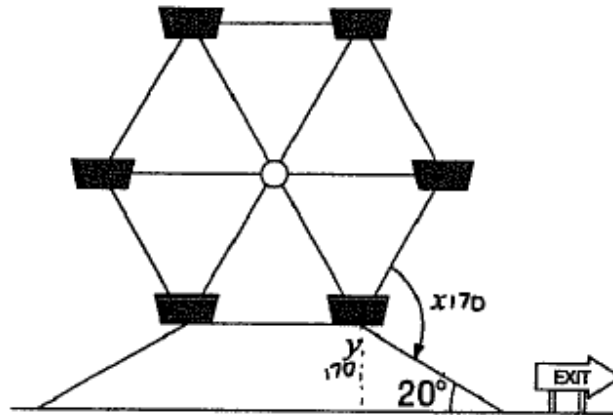

What are the values of x and y ?

Use geometric properties to justify your answer.

$$P = a + b + c$$

$$P = x + y + 20$$

$$P = 360$$

$$P = 360 - 20$$

$$P = 340$$

$$P = 340 \div 2$$

$$P = 170$$

0
60 The value of x and y is
both 170°

Annotation:

Problem solving process demonstrates limited identification of important elements of the problem; values for both x and y incorrect and incorrectly assumes that $x + y + 20^\circ = 360^\circ$.

A Ferris wheel has six sides of equal length. The exit ramp of the Ferris wheel is in the shape of a trapezoid and has an angle of incline of 20° .

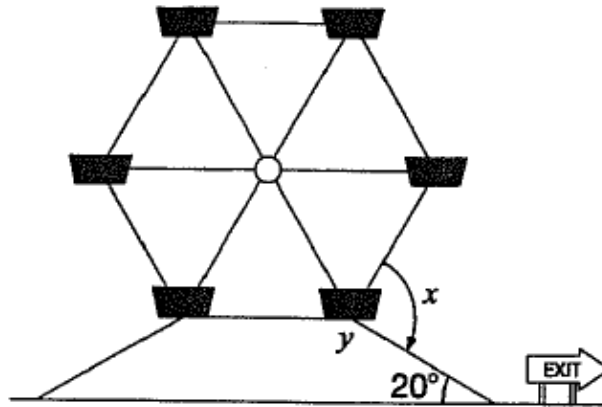

What are the values of x and y ?

Use geometric properties to justify your answer.

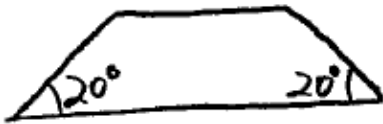

$$360^\circ - 40^\circ = 320^\circ$$

$$y = 320^\circ \div 2$$

$$y = 160^\circ$$

$$x = 180^\circ$$

Annotation:

Problem solving process demonstrates identification of some of the important elements of the problem; value for y correct with justification but assumes that the base angles are equal and value for x is incorrect.

A Ferris wheel has six sides of equal length. The exit ramp of the Ferris wheel is in the shape of a trapezoid and has an angle of incline of 20° .

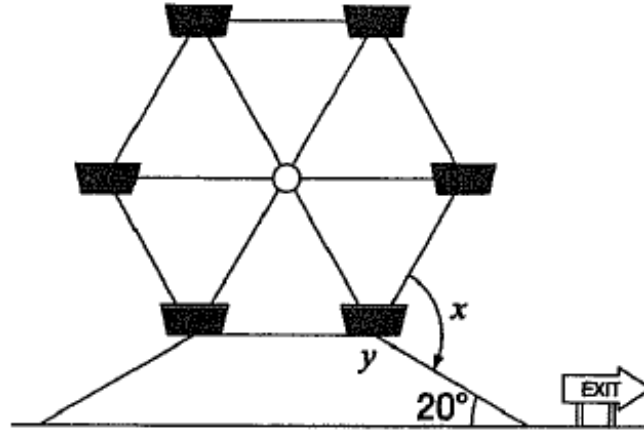

What are the values of x and y ?

Use geometric properties to justify your answer.

$$y = 180^\circ - 20^\circ \text{ (C-pattern)}$$

$$= 160^\circ$$

$$x = 360^\circ - 280^\circ$$

$$= 80^\circ$$

Annotation:

Problem solving process demonstrates appropriate conclusions with supporting evidence; values for x and y are correct and with justification for y , but justification for x is not clear (no evidence of how 280° was calculated).

A Ferris wheel has six sides of equal length. The exit ramp of the Ferris wheel is in the shape of a trapezoid and has an angle of incline of 20° .

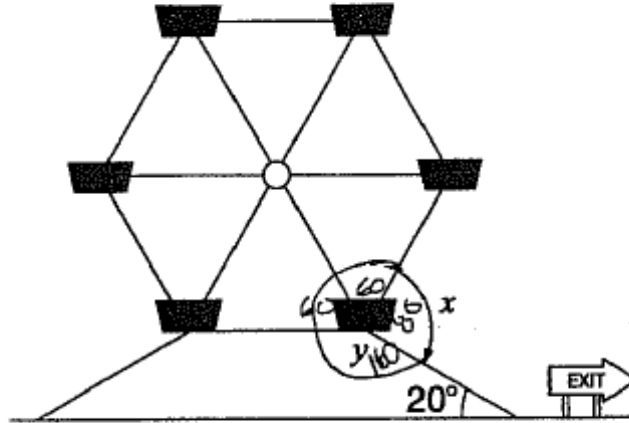

What are the values of x and y ?

Use geometric properties to justify your answer.

$$y = 180 - 20 = 160$$

$$\therefore y = 160 \text{ and } x = 80$$

$$x = 360 - 160 - 60 - 60 = 80$$

Annotation:

Problem solving process demonstrates appropriate conclusions with thorough and insightful supporting evidence; values for both x and y are correct with justification for both (uses parallel lines to determine y and sum of angles in a polygon to determine x).