

Question 7

Code	Descriptor
B	<ul style="list-style-type: none"> • Blank: nothing written or drawn in response to the question
I	<ul style="list-style-type: none"> • Illegible: cannot be read; completely crossed out / erased; not written in English • Irrelevant content: does not attempt assigned question (e.g., comment on the task, drawings, “?”, “!”, “I don’t know”) • Off topic: no relationship of written work to the question
10	<p>Problem-solving process to predict the frequency of an outcome of a simple probability experiment or game, by calculating and using the theoretical probability of that outcome shows limited effectiveness due to</p> <ul style="list-style-type: none"> • minimal evidence of a solution process • limited identification of important elements of the problem • too much emphasis on unimportant elements of the problem • no conclusions presented • conclusion presented without supporting evidence
20	<p>Problem-solving process to predict the frequency of an outcome of a simple probability experiment or game, by calculating and using the theoretical probability of that outcome shows some effectiveness due to</p> <ul style="list-style-type: none"> • an incomplete solution process • identification of some of the important elements of the problem • some understanding of the relationships between important elements of the problem • simple conclusions with little supporting evidence
30	<p>Problem-solving process to predict the frequency of an outcome of a simple probability experiment or game, by calculating and using the theoretical probability of that outcome shows considerable effectiveness due to</p> <ul style="list-style-type: none"> • a solution process that is nearly complete • identification of most of the important elements of the problem • a considerable understanding of the relationships between important elements of the problem • appropriate conclusions with supporting evidence
40	<p>Problem-solving process to predict the frequency of an outcome of a simple probability experiment or game, by calculating and using the theoretical probability of that outcome shows a high degree of effectiveness due to</p> <ul style="list-style-type: none"> • a complete solution process • identification of all important elements of the problem • a thorough understanding of the relationships between all of the important elements of the problem • appropriate conclusions with thorough and insightful supporting evidence

Assessments of Reading, Writing and Mathematics, Junior Division
Anchor Set and Rationales for Mathematics Open-Response
Question 7

10

Lori has a bag of 24 gumballs. She takes 8 gumballs from the bag without looking. The colours of the 8 gumballs Lori takes from the bag are 4 red, 3 blue and 1 yellow.

Using the colours of the gumballs Lori takes from the bag, predict how many gumballs of each colour were in the bag to start.

Explain your thinking.

I think Lori has 9 red, 6 blue and 5 yellow,
because it all adds up evenly.

Rationale: Student demonstrates minimal evidence of a solution process; understands the concept of relative number of gumballs but does not take into consideration the total number of gumballs.

Assessments of Reading, Writing and Mathematics, Junior Division
Anchor Set and Rationales for Mathematics Open-Response
Question 7

20

Lori has a bag of 24 gumballs. She takes 8 gumballs from the bag without looking. The colours of the 8 gumballs Lori takes from the bag are 4 red, 3 blue and 1 yellow.

Using the colours of the gumballs Lori takes from the bag, predict how many gumballs of each colour were in the bag to start.

Explain your thinking.

I predict that there are 8 of each colour because there are 3 colours and 24 gumballs. I know that $8 \times 3 = 24$ that is why I predicted 8.

Rationale: Student identifies some of the important elements of the problem; divides 24 gumballs equally to show proportionality but demonstrates an incomplete solution process.

Assessments of Reading, Writing and Mathematics, Junior Division
Anchor Set and Rationales for Mathematics Open-Response
Question 7

20

Lori has a bag of 24 gumballs. She takes 8 gumballs from the bag without looking. The colours of the 8 gumballs Lori takes from the bag are 4 red, 3 blue and 1 yellow.

Using the colours of the gumballs Lori takes from the bag, predict how many gumballs of each colour were in the bag to start.

Explain your thinking.

12 red 8 blue 4 yellow
I went by which numbers come
up the most and just added
different numbers and got
my numbers

Rationale: Student demonstrates some understanding of the relationships between important elements of the problem; chooses numbers that total 24 and orders the colours correctly but does not provide explanation for the numbers or demonstrate proportionality.

Assessments of Reading, Writing and Mathematics, Junior Division
Anchor Set and Rationales for Mathematics Open-Response
Question 7

30

Lori has a bag of 24 gumballs. She takes 8 gumballs from the bag without looking. The colours of the 8 gumballs Lori takes from the bag are 4 red, 3 blue and 1 yellow.

Using the colours of the gumballs Lori takes from the bag, predict how many gumballs of each colour were in the bag to start.

Explain your thinking.

$$\begin{array}{l} 4 \times 3 = 12 \text{ red} \\ 3 \times 3 = 9 \text{ blue} \\ 1 \times 3 = 3 \text{ yellow} \end{array}$$

Rationale: Student provides a solution process that is nearly complete; does not explain where the multiplier 3 comes from but solution does show proportionality and relative numbers that total 24.

Assessments of Reading, Writing and Mathematics, Junior Division
Anchor Set and Rationales for Mathematics Open-Response
Question 7

40

Lori has a bag of 24 gumballs. She takes 8 gumballs from the bag without looking. The colours of the 8 gumballs Lori takes from the bag are 4 red, 3 blue and 1 yellow.

Using the colours of the gumballs Lori takes from the bag, predict how many gumballs of each colour were in the bag to start.

Explain your thinking.

$$\begin{array}{r} 3 \\ 8 \overline{)24} \\ \underline{24} \\ 0 \end{array}$$

$$\begin{array}{l} 4 \times 3 = 12 \\ 3 \times 3 = 9 \\ 1 \times 3 = 3 \end{array}$$

12 reds,
9 blue,
3 yellow

Rationale: Student demonstrates a solution process that is complete; shows thorough understanding of proportionality and relative numbers and arrives at the correct solution

Question 8

Code	Descriptor
B	<ul style="list-style-type: none"> • Blank: nothing written or drawn in response to the question
I	<ul style="list-style-type: none"> • Illegible: cannot be read; completely crossed out / erased; not written in English • Irrelevant content: does not attempt assigned question (e.g., comment on the task, drawings, “?”, “!”, “I don’t know”) • Off topic: no relationship of written work to the question
10	<p>Problem-solving process to represent relationships using unit rates shows limited effectiveness due to</p> <ul style="list-style-type: none"> • minimal evidence of a solution process • limited identification of important elements of the problem • too much emphasis on unimportant elements of the problem • no conclusions presented • conclusion presented without supporting evidence
20	<p>Problem-solving process to represent relationships using unit rates shows some effectiveness due to</p> <ul style="list-style-type: none"> • an incomplete solution process • identification of some of the important elements of the problem • some understanding of the relationships between important elements of the problem • simple conclusions with little supporting evidence
30	<p>Problem-solving process to represent relationships using unit rates shows considerable effectiveness due to</p> <ul style="list-style-type: none"> • a solution process that is nearly complete • identification of most of the important elements of the problem • a considerable understanding of the relationships between important elements of the problem • appropriate conclusions with supporting evidence
40	<p>Problem-solving process to represent relationships using unit rates shows a high degree of effectiveness due to</p> <ul style="list-style-type: none"> • a complete solution process • identification of all important elements of the problem • a thorough understanding of the relationships between all of the important elements of the problem • appropriate conclusions with thorough and insightful supporting evidence

Assessments of Reading, Writing and Mathematics, Junior Division
Anchor Set and Rationales for Mathematics Open-Response
Question 8

10

A school needs to buy 2400 pencils. The prices for pencils at 3 stores are shown below.

- Store A sells 60 pencils for \$1.80.
- Store B sells 30 pencils for \$0.99.
- Store C sells 15 pencils for \$0.55.

The school will purchase the pencils with the lowest price. Which store has the lowest price for 2400 pencils?

Explain your answer.

I know this because store A has more pencils in the package and has the best price, because for store B you'll have to buy more packages to pay more. there for you have

Store A has the lowest price for pencils.

Rationale: Student demonstrates a limited identification of important elements of the problem; chooses store A because it has more pencils in the packages and does not address the relationship between the cost and amount of pencils.

Assessments of Reading, Writing and Mathematics, Junior Division
Anchor Set and Rationales for Mathematics Open-Response
Question 8

20

A school needs to buy 2400 pencils. The prices for pencils at 3 stores are shown below.

- Store A sells 60 pencils for \$1.80.
- Store B sells 30 pencils for \$0.99.
- Store C sells 15 pencils for \$0.55.

The school will purchase the pencils with the lowest price. Which store has the lowest price for 2400 pencils?

Explain your answer.

A $60 \times 40 = 2400$
 $1.80 \times 40 = 72.00$
The cost will be
72.00

Store A has the lowest price for pencils.

Rationale: Student provides an incomplete solution; completes an accurate calculation for the cost of pencils for one store only and reaches a simple conclusion with little supporting evidence.

Assessments of Reading, Writing and Mathematics, Junior Division
Anchor Set and Rationales for Mathematics Open-Response
Question 8

20

A school needs to buy 2400 pencils. The prices for pencils at 3 stores are shown below.

- Store A sells 60 pencils for \$1.80.
- Store B sells 30 pencils for \$0.99.
- Store C sells 15 pencils for \$0.55.

The school will purchase the pencils with the lowest price. Which store has the lowest price for 2400 pencils?

Explain your answer.

Store C sells 15 pencils in a pack so you
need to buy 160 packs for 15 pack for 8.25\$

Store C has the lowest price for pencils.

Rationale: Student provides an incomplete solution process; for store C, identifies the number of packages needed to make 2400 without recording calculations. Reaches a simple conclusion with little supporting evidence.

Assessments of Reading, Writing and Mathematics, Junior Division
Anchor Set and Rationales for Mathematics Open-Response
Question 8

30

A school needs to buy 2400 pencils. The prices for pencils at 3 stores are shown below.

- Store A sells 60 pencils for \$1.80.
- Store B sells 30 pencils for \$0.99.
- Store C sells 15 pencils for \$0.55.

The school will purchase the pencils with the lowest price. Which store has the lowest price for 2400 pencils?

Explain your answer.

~~A~~ $60 \times 40 = 2400$ (B) $30 \times 80 = 2400$ (C) $15 \times 160 = 2400$
0.03 0.033 0.036

Store A has the lowest price for pencils.

Rationale: Student provides a solution process that is nearly complete; identifies number of packages needed for 2400 pencils, but does not use this strategy to choose store A. Does not show how they have calculated unit rate (cost per pencil) or give a reason for choosing store A.

**Assessments of Reading, Writing and Mathematics, Junior Division
Anchor Set and Rationales for Mathematics Open-Response
Question 8**

30

A school needs to buy 2400 pencils. The prices for pencils at 3 stores are shown below.

- Store A sells 60 pencils for \$1.80.
- Store B sells 30 pencils for \$0.99.
- Store C sells 15 pencils for \$0.55.

The school will purchase the pencils with the lowest price. Which store has the lowest price for 2400 pencils?

Explain your answer.

Store A has the lowest price. I knew this because I added up every thing to see what store would have the lowest prices.

Store _____ has the lowest price for pencils.

<p style="text-align: center;"><u>Store A</u></p> $\begin{array}{r} 60 \\ \times 40 \\ \hline 2400 \\ +2400 \\ \hline 2400 \end{array}$ $\begin{array}{r} 3 \\ \times 1.80 \\ \hline 0.00 \\ 00.00 \\ 000.00 \\ \hline 72,000.00 \end{array}$ <p>Total: <u>\$72,000.00</u></p>	<p style="text-align: center;"><u>Store B</u></p> $\begin{array}{r} 30 \\ \times 80 \\ \hline 2400 \\ +2400 \\ \hline 2400 \end{array}$ $\begin{array}{r} 0.99 \\ \times 80.00 \\ \hline 0.00 \\ 00.00 \\ 000.00 \\ \hline 8,200.00 \end{array}$ <p>Total: <u>\$81,200.00</u></p>	<p style="text-align: center;"><u>Store C</u></p> $\begin{array}{r} 3 \\ \times 160 \\ \hline 900 \\ 1500 \\ \hline 2400 \end{array}$ $\begin{array}{r} 3 \\ \times 0.55 \\ \hline 0.00 \\ 3300.00 \\ 5500.00 \\ \hline 8800.00 \end{array}$ <p>Total: <u>\$80,000.00</u></p>
--	---	---

Rationale: Student demonstrates a considerable understanding of the relationships between important elements of the problem; identifies number of packages needed for 2400 pencils. Utilizes a correct process to determine the total cost for 2400 pencils; however, error in placement of decimal place leads to an unreasonable total cost.

Assessments of Reading, Writing and Mathematics, Junior Division
Anchor Set and Rationales for Mathematics Open-Response
Question 8

40

A school needs to buy 2400 pencils. The prices for pencils at 3 stores are shown below.

- Store A sells 60 pencils for \$1.80.
- Store B sells 30 pencils for \$0.99.
- Store C sells 15 pencils for \$0.55.

The school will purchase the pencils with the lowest price. Which store has the lowest price for 2400 pencils?

Explain your answer.

I divided the price with
the amount of pencils.

$$1.80 \div 60 = 3$$

$$.99 \div 30 = 3.3$$

$$.55 \div 15 = 3.6$$

Store A has the lowest price for pencils.

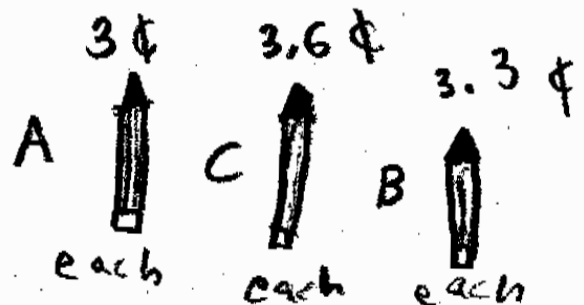

Rationale: Student demonstrates a thorough understanding of the relationships between all of the important elements of the problem and provides an appropriate conclusion with thorough and insightful supporting evidence; successfully represents relationships using unit rates (cost per pencil).

**Assessments of Reading, Writing and Mathematics, Junior Division
Anchor Set and Rationales for Mathematics Open-Response
Question 8**

40

A school needs to buy 2400 pencils. The prices for pencils at 3 stores are shown below.

- Store A sells 60 pencils for \$1.80.
- Store B sells 30 pencils for \$0.99.
- Store C sells 15 pencils for \$0.55.

The school will purchase the pencils with the lowest price. Which store has the lowest price for 2400 pencils?

Explain your answer.

Store A

$$\begin{array}{r} 2400 \\ \div 60 \\ \hline 40 \\ \\ 40 \\ \times 1.80 \\ \hline \$72.00 \end{array}$$

Store B

$$\begin{array}{r} 2400 \\ \div 30 \\ \hline 80 \\ \\ 80 \\ \times 0.99 \\ \hline \$80.81 \end{array}$$

Store C

$$\begin{array}{r} 2400 \\ \div 15 \\ \hline 160 \\ \\ 160 \\ \times 0.55 \\ \hline \$88.00 \end{array}$$

Store A has the lowest price for pencils.

Rationale: Student demonstrates a complete solution process and identifies all important elements of the problem; identifies the number of packages needed to make 2400 and utilizes a correct process to determine the cost for 2400 pencils. Minor calculation error for store B does not detract from a complete understanding of the relationship between important elements of the problem (should be \$79.20 instead of \$80.81)

Question 9

Code	Descriptor
B	<ul style="list-style-type: none"> • Blank: nothing written or drawn in response to the question
I	<ul style="list-style-type: none"> • Illegible: cannot be read; completely crossed out/erased; not written in English • Irrelevant content: does not attempt assigned question (e.g., comment on the task, drawings, “?”, “!”, “I don’t know”) • Off topic: no relationship of written work to the question
10	<p>Application of knowledge and skills to construct polygons given angle and side measurements shows limited effectiveness due to</p> <ul style="list-style-type: none"> • misunderstanding of concepts • incorrect selection or misuse of procedures
20	<p>Application of knowledge and skills to construct polygons given angle and side measurements shows some effectiveness due to</p> <ul style="list-style-type: none"> • partial understanding of the concepts • errors and/or omissions in the application of the procedures
30	<p>Application of knowledge and skills to construct polygons given angle and side measurements shows considerable effectiveness due to</p> <ul style="list-style-type: none"> • an understanding of most of the concepts • minor errors and/or omissions in the application of the procedures
40	<p>Application of knowledge and skills to construct polygons given angle and side measurements shows a high degree of effectiveness due to</p> <ul style="list-style-type: none"> • a thorough understanding of the concepts • an accurate application of the procedures (any minor errors and/or omissions do not detract from the demonstration of a thorough understanding)

Assessments of Reading, Writing and Mathematics, Junior Division
Anchor Set and Rationales for Mathematics Open-Response
Question 9

10

Using a ruler and protractor, draw a right trapezoid with a side measure of 5 cm. Measure and label all angles.

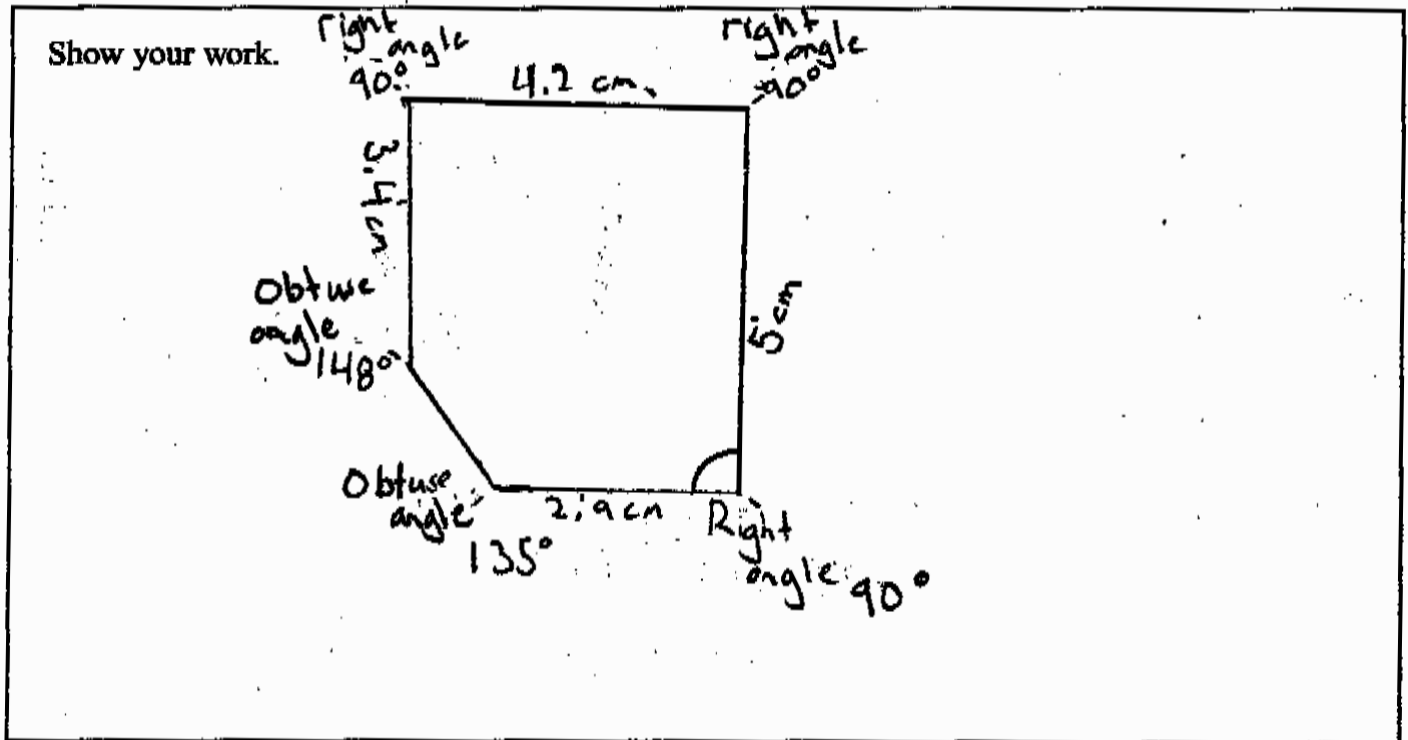

Rationale: The student demonstrates a misunderstanding of concepts; draws a 5 sided figure with a 5 cm side measure and a right angle.

Assessments of Reading, Writing and Mathematics, Junior Division
Anchor Set and Rationales for Mathematics Open-Response
Question 9

20

Using a ruler and protractor, draw a **right trapezoid** with a side measure of 5 cm. Measure and label all angles.

Show your work.

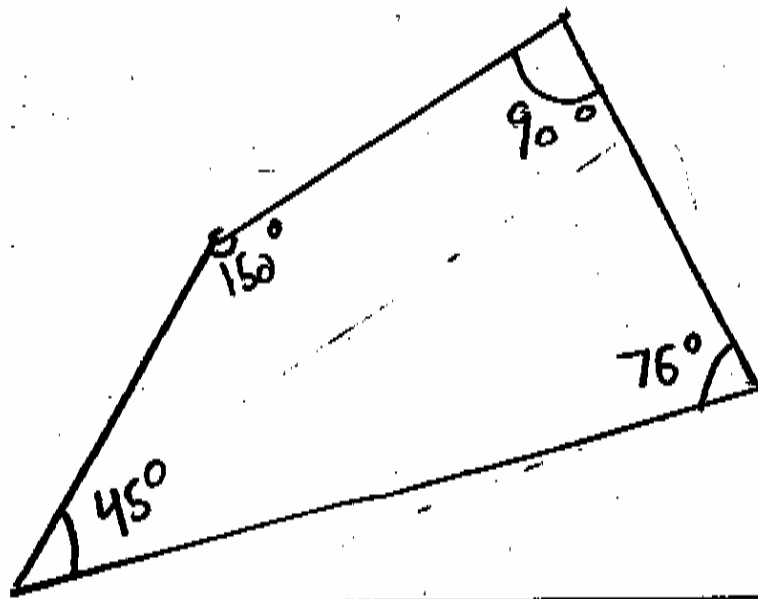

Rationale: The student demonstrates a partial understanding of the concepts and makes errors in the application of the procedures; draws a quadrilateral (not a trapezoid) with a 90° angle and a 5 cm side measure.

Assessments of Reading, Writing and Mathematics, Junior Division
Anchor Set and Rationales for Mathematics Open-Response
Question 9

20

Using a ruler and protractor, draw a **right** trapezoid with a side measure of 5 cm. Measure and label all angles.

Show your work.

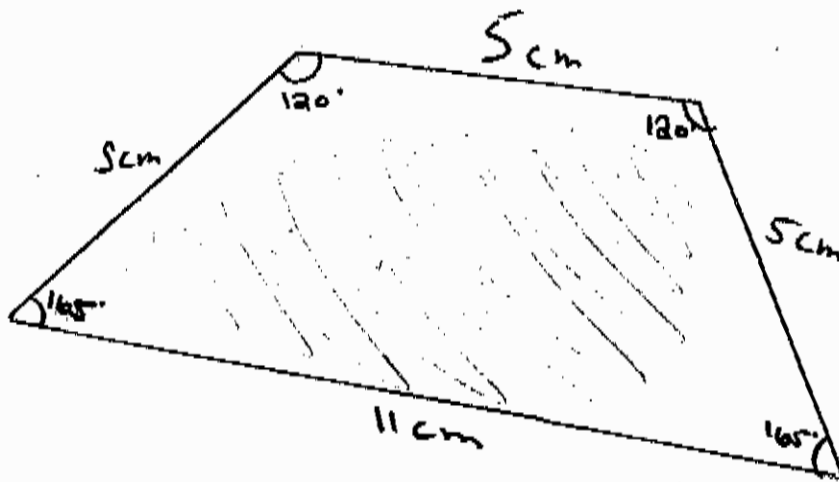

Rationale: Student demonstrates a partial understanding of the concepts and makes errors in the application of the procedures; construct a trapezoid with a 5 cm side. Does not measure angles correctly or include 90° angles.

Assessments of Reading, Writing and Mathematics, Junior Division
Anchor Set and Rationales for Mathematics Open-Response
Question 9

30

Using a ruler and protractor, draw a right trapezoid with a side measure of 5 cm. Measure and label all angles.

Show your work.

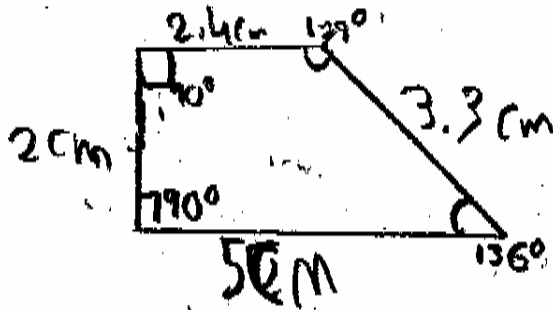

Rationale: The student demonstrates a considerable understanding of most of the concepts with minor errors; draws a trapezoid with 90° and 5 cm side measure; however, measures the two non 90° incorrectly ($44^\circ + 129^\circ = 173^\circ$ - out by 7°) ($> 5^\circ$ allowed)

Assessments of Reading, Writing and Mathematics, Junior Division
Anchor Set and Rationales for Mathematics Open-Response
Question 9

30

Using a ruler and protractor, draw a **right** trapezoid with a side measure of 5 cm. Measure and label all angles.

Show your work.

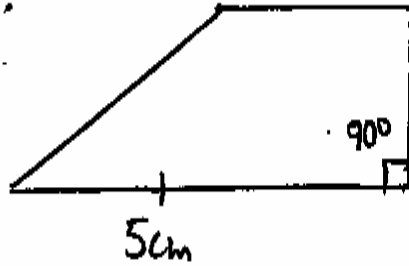

Rationale: The student demonstrates a considerable understanding of most of the concepts with minor omissions; draws a trapezoid with a 90° angle and a 5 cm side measure but does not measure and label the angles.

Assessments of Reading, Writing and Mathematics, Junior Division
Anchor Set and Rationales for Mathematics Open-Response
Question 9

40

Using a ruler and protractor, draw a **right** trapezoid with a side measure of 5 cm. Measure and label all angles.

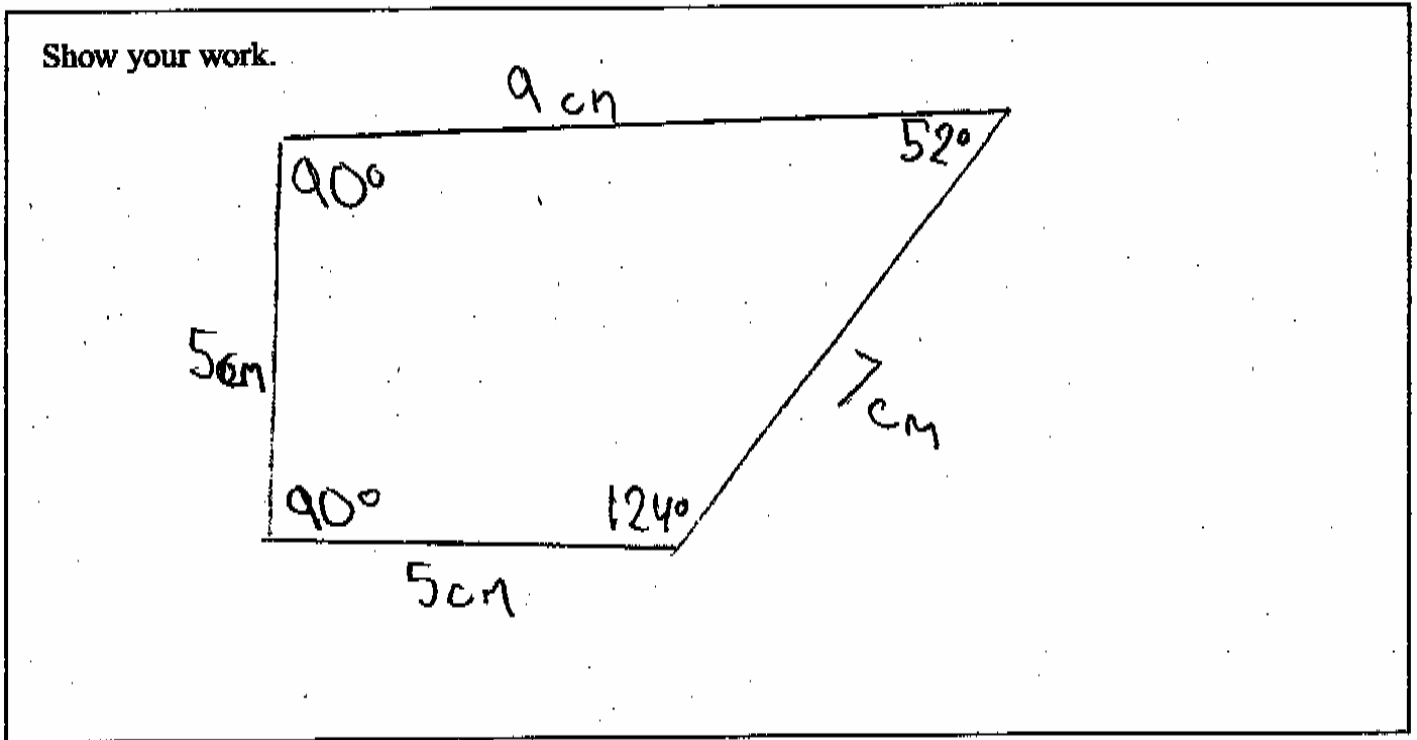

Rationale: The student demonstrates a thorough understanding of the concepts and an accurate application of the procedures; the angle measurements are within a 5° variance ($124^\circ + 52^\circ = 176^\circ$, a difference of 5°).

Question 10

Code	Descriptor
B	<ul style="list-style-type: none"> • Blank: nothing written or drawn in response to the question
I	<ul style="list-style-type: none"> • Illegible: cannot be read; completely crossed out/erased; not written in English • Irrelevant content: does not attempt assigned question (e.g., comment on the task, drawings, “?”, “!”, “I don’t know”) • Off topic: no relationship of written work to the question
10	<p>Problem-solving process to solve problems involving the estimation and calculation of the surface area and volume of triangular and rectangular prisms shows limited effectiveness due to</p> <ul style="list-style-type: none"> • minimal evidence of a solution process • limited identification of important elements of the problem • too much emphasis on unimportant elements of the problem • no conclusions presented • conclusion presented without supporting evidence
20	<p>Problem-solving process to solve problems involving the estimation and calculation of the surface area and volume of triangular and rectangular prisms shows some effectiveness due to</p> <ul style="list-style-type: none"> • an incomplete solution process • identification of some of the important elements of the problem • some understanding of the relationships between important elements of the problem • simple conclusions with little supporting evidence
30	<p>Problem-solving process to solve problems involving the estimation and calculation of the surface area and volume of triangular and rectangular prisms shows considerable effectiveness due to</p> <ul style="list-style-type: none"> • a solution process that is nearly complete • identification of most of the important elements of the problem • a considerable understanding of the relationships between important elements of the problem • appropriate conclusions with supporting evidence
40	<p>Problem-solving process to solve problems involving the estimation and calculation of the surface area and volume of triangular and rectangular prisms shows a high degree of effectiveness due to</p> <ul style="list-style-type: none"> • a complete solution process • identification of all important elements of the problem • a thorough understanding of the relationships between all of the important elements of the problem • appropriate conclusions with thorough and insightful supporting evidence

Assessments of Reading, Writing and Mathematics, Junior Division
Anchor Set and Rationales for Mathematics Open-Response
Question 10

10

Jude's fish tank, shown below, holds $100\,000\text{ cm}^3$ of water when full. Jude decides to pour in water to a height of 5 cm below the top of the tank.

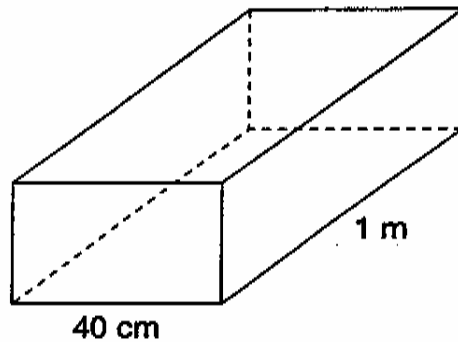

How much water, in cm^3 , will Jude need to pour into the tank so that the water is 5 cm below the top?

Show your work.

$$40\text{ cm} \times 1\text{ m} = 100\,000\text{ cm}^3$$

$$35\text{ cm} \times 1\text{ m} = 95,995\text{ cm}^3$$

Jude needs to pour $95,995\text{ cm}^3$ of water in the tank so that the water is 5 cm below the top.

Rationale: Student demonstrates minimal evidence of a solution process; subtracts 5 cm from the width and results in a volume that is not explained.

Assessments of Reading, Writing and Mathematics, Junior Division
Anchor Set and Rationales for Mathematics Open-Response
Question 10

20

Jude's fish tank, shown below, holds $100\,000\text{ cm}^3$ of water when full. Jude decides to pour in water to a height of 5 cm below the top of the tank.

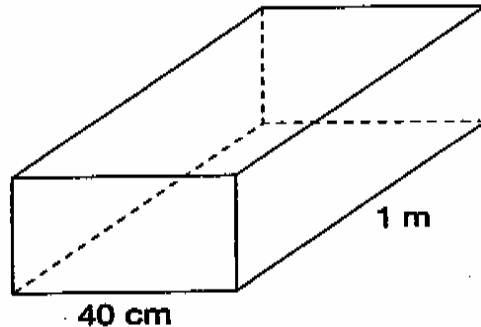

How much water, in cm^3 , will Jude need to pour into the tank so that the water is 5 cm below the top?

Show your work.

$$\begin{aligned} \textcircled{1} 1\text{ cm}^3 &= 1\text{ mL} & \textcircled{2} 100,000\text{ cm}^3 &= 100,000\text{ mL} \div 5\text{ cm} = 20,000 \\ \textcircled{3} 100,000\text{ mL} &- 20,000\text{ mL} &= 80,000 \\ && 80,000\text{ cm}^3 \end{aligned}$$

Rationale: Student provides a solution process that shows some understanding of the relationship between important elements of the problem; determines missing volume by an inappropriate strategy but correctly subtracts this volume from total.

Assessments of Reading, Writing and Mathematics, Junior Division
Anchor Set and Rationales for Mathematics Open-Response
Question 10

20

Jude's fish tank, shown below, holds $100\,000\text{ cm}^3$ of water when full. Jude decides to pour in water to a height of 5 cm below the top of the tank.

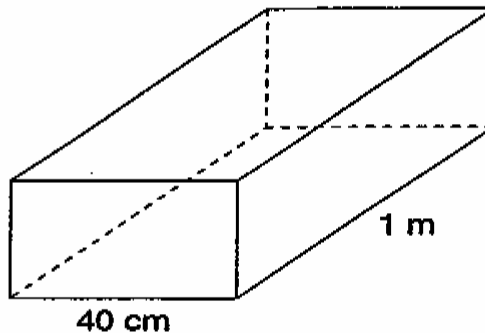

How much water, in cm^3 , will Jude need to pour into the tank so that the water is 5 cm below the top?

Show your work.

$$40 \times 100 = 4000\text{ cm}^3$$

$$\begin{array}{r} 4000\text{ cm}^3 \\ - 5\text{ cm}^3 \\ \hline 3995\text{ cm}^3 \end{array}$$

Jude will need 3995 cm^3 of water to fill the tank 5 cm below the top.

Rationale: Student demonstrates a solution process that shows some understanding of the relationships between important elements of the problem; converts units (m to cm) and finds the area of the base but cannot use the information to determine the missing height or the new volume of the fish tank.

Assessments of Reading, Writing and Mathematics, Junior Division
 Anchor Set and Rationales for Mathematics Open-Response
 Question 10

30

Jude's fish tank, shown below, holds $100\,000\text{ cm}^3$ of water when full. Jude decides to pour in water to a height of 5 cm below the top of the tank.

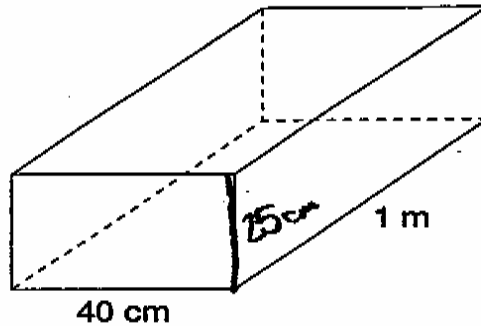

How much water, in cm^3 , will Jude need to pour into the tank so that the water is 5 cm below the top?

Show your work.

Handwritten student work:

$$40\text{ cm} \times 100\text{ cm} = 4000\text{ cm}^2$$

$$h = 25\text{ cm}$$

$$W = 1\text{ m} = 100\text{ cm}$$

$$L = 40\text{ cm}$$

$$40 \times 100 \times 25 = 100\,000 = V$$

$$h = 25$$

$$- 5\text{ cm}$$

$$20\text{ cm}$$

$$100\,000 \div 20 = 5000\text{ cm}^3$$

Jude needs to put in 5000 cm^3 of water.

Rationale: Student demonstrates a solution process that is nearly complete; verifies that a height of 25 cm will result in a volume of $100\,000\text{ cm}^3$; determines that the new height is 20 cm but chooses an incorrect procedure to calculate the new volume.

Assessments of Reading, Writing and Mathematics, Junior Division
Anchor Set and Rationales for Mathematics Open-Response
Question 10

30

Jude's fish tank, shown below, holds $100\,000\text{ cm}^3$ of water when full. Jude decides to pour in water to a height of 5 cm below the top of the tank.

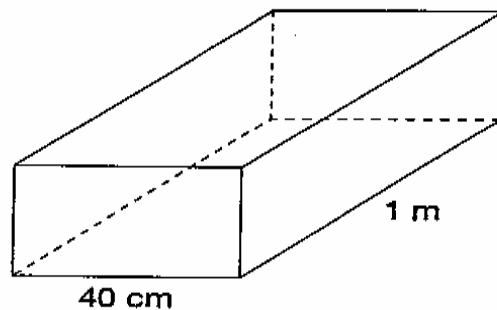

How much water, in cm^3 , will Jude need to pour into the tank so that the water is 5 cm below the top of the tank?

Show your work.

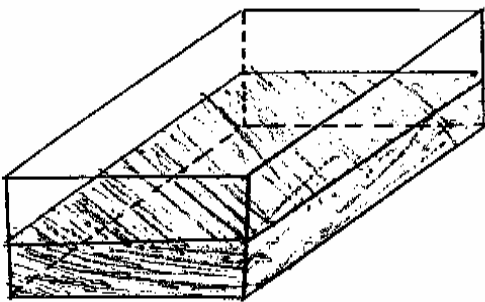

 = water

$$40 \times 100 \times 20 = 80000\text{ cm}^3$$

He needs to pour 80000 cm^3 .

Rationale: Student demonstrates a solution process that is nearly complete; determines the new volume of the fish tank but does not show how they have determined the height.

Assessments of Reading, Writing and Mathematics, Junior Division
Anchor Set and Rationales for Mathematics Open-Response
Question 10

40

Jude's fish tank, shown below, holds $100\,000\text{ cm}^3$ of water when full. Jude decides to pour in water to a height of 5 cm below the top of the tank.

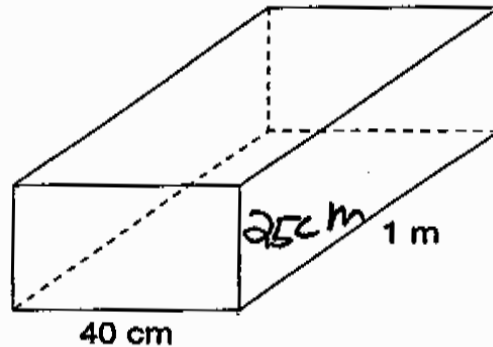

How much water, in cm^3 , will Jude need to pour into the tank so that the water is 5 cm below the top?

Show your work.

$$\begin{aligned}1\text{ m} &= 100\text{ cm} \\40 \times 100 &= 4000\text{ cm} \\100\,000 \div 4000 &= 25 \\40 \times 100 \times 20 &= 80000\text{ cm}^3\end{aligned}$$

Rationale: Student demonstrates a complete solution process; determines the height of the fish tank and recalculates the required volume.